

Organization of ITI's and scope of the electrician trade

Objectives: At the end of this lesson you shall be able to

- state brief introduction about Industrial Training Institutes (ITI)
- state about the organized structure of the Institute.

Brief Introduction of Industrial Training Institute (ITIs)

Industrial Training Institute plays a vital role in economy of the country, especially in terms of providing skilled manpower.

The Directorate General of Training (DGT) comes under **Ministry of Skill Development and Entrepreneurship (MSDE)** offers a range of vocational training trades in different sectors based on economy/labour market. The vocational training programs are delivered under the aegis of **National Council of Vocational Training (NCVT)**. Craftsman Training scheme (CTS) and Apprenticeship Training Scheme (ATS) and two pioneer programs of NCVT for Propagatory Vocational Training.

They are giving training about 132 trades including Engineering and Non-engineering with the duration of 1 or 2 years. The minimum eligibility for admission in ITIs 8th, 10th and 12th pass with respect to the trades and admission process will be held in every year.

At the end of each year, All India Trade Test (AITT) will be conducted in multiple choice type questions. After passing, National trade certificates (NTC), will be issued by DGT which is authorized and recognized internationally. In 2017, for some trades they have introduced and implemented

National Skill Qualification Framework (NSQF) with Level 4 and Level 5.

After finishing instructional training with 'NTC' certificate, they have to undergo Apprenticeship training (ATS) for one or two year in respective trades under the Apprentice ACT 1961, in various government and private establishments with stipend. At the end of the Apprenticeship training, All India Apprentice Test will be conducted and apprentice certificate will be issued. They can get job opportunities in private or government establishment in India/Abroad or they can start small scale industries in manufacturing or in service sector with subsidiary government loan.

Organizational Structure of ITIs : In most of the ITIs, the head of the institute is the principal under him one vice-principal (VP). then Training Officers (TO)/Group Instructors (GI) who are the management and supervisory staff. Then Assistant Training Officers (ATO), Junior Training Officer (JTO), and Vocational Instructors (VI) are under Training officers for each trade and for Workshop calculations, Engineering Drawing, Employability skills etc. Administrative staff, Hostel Superintendent (H.S.) physical Education Trainer (PET), Library incharge, Pharmacist, etc. will be under the head of the Institution.

Scope of the electrician trade

Objectives: At the end of this lesson you shall be able to

- explain the duties of electrician general and electrical fitter and their NCO
- state the key skills and carrier pathway for electrician
- list out the job opportunities and self employment opportunities.

Welcome to the electrician trade : Electrician trade under craftsman training scheme (CTS) is one of the most popular trade delivered nationwide through the network of ITIs. This trade is of two year duration.

It mainly consists of domain area and core areas. In domain area trade practical and trade theory and core area workshop calculation and science, Engineering drawing and employability skills which imparts soft and life skills. There are two professional classification in electrician trade based on National Code of Occupation (NCO) as

- Electrician general (NCO - 2015 reference is 7411.0100)
- Electrical fitter (NCO - 2015 reference is 7412.0200)

Duties of Electrician - General and Electrical - Fitter, Electrician - General installs, maintains and repairs electrical machinery, equipment and fittings in factories, workshops, power houses, business and residential premises, etc. Studies drawings and other specifications

to determine electrical circuit, installation etc. Positions and installs electrical motors, transformers, switchboards, microphones, loud-speakers and other electrical equipment, fittings and lighting fixtures. Makes connections and solder terminals. Tests electrical installations and equipment and locates faults using megger, test lamp etc.

Repairs or replaces defective wiring, burnt out fuses and defective parts and keeps fittings and fixtures in working order. may do armature winding, draw wires and cables and do simple cable joining. May operate, attend and maintain electrical motors, pumps etc. NCO - 2015 reference is 7411.0100

Record class of work in which experienced such as factory, power-house, ship etc., whether experienced in electrical repairs or detecting faults, details of experience in electrical equipment such as sound recording apparatus, air purification plant, heating apparatus etc. whether used to working do drawing, whether accustomed to high tension

or low tension supply system and if in possession of competency certificate issued under electricity act.

Electrical fitter fits and assembles electrical machinery and equipment such as motors, transformers, generators, switch gears, fans, etc., Studies drawings and wiring diagrams of fittings, wiring and assemblies to be made.

Erects various equipment such as bus bars, panel board, electrical post, fuse boxes switch gears, meters, relays etc., using non-conductors, insulating and hoisting equipment as necessary for receipt and distribution of electrical current to feeder lines.

Record nature of work done; if specialized in repairing or assembling any particular item such as generator, motor, transformer, relays switchgear, domestic appliance etc. , experience of working in power-house and distribution centre and if in possession of electrician's competency certificate

Key Skills of Electrician

After passing the electrician trade, they are able to

- Read and interpret technical parameter documents, plan and organic work process, identify necessary materials and tools
- Apply professional skill knowledge and employability skills while performing jobs.
- Checking job/assembly as per drawing for functioning, identifying and rectifying errors in job/assembly.
- Document the technical parameters related to the tasks undertaken

Presently electrician syllabus again Revised and sequentially structured by National Skill Qualification Framework NSQF - level 5 and implemented from August 2017

Carrier Progress Pathways

After passing the electrician trade the trainee can appear in 10+2 examination through National Institute of Open

Schooling (NIOS) for acquiring higher secondary certificate and can go further for general Technical education.

- Take admission in diploma course in notified branches of engineering by lateral entry
- Can join the apprenticeship training in different types of industries and obtain National Apprenticeship Certificate (NAC)
- Eligible to obtain directly wireman 'B' license, which is issued by the Electrical Licensing Board Authorities

Job Opportunities: There are good numbers of job opportunities for an electrician

- Electrician in local electricity boards, railways, Telephone department, airport and other government and semi-government establishments
- Electrician in factories (Public/Private) Install, test and maintain electrical equipment in auditorium and cinema halls
- Winder of electrical motors in winding shops
- Electrical appliances repairer in electrical shops.
- Electrician to Install, service and maintain electrical equipment and circuits in hotels, resorts hospitals and flats

Self-employment opportunities

- Service centre for repairing electrical switch gear and motors in rural and urban areas.
- Maintenance contractor of wiring installation in hotels/ resorts/hospitals/banks etc.
- Manufacturer of sub-assembly for electrical panels
- Contractor for domestic wiring and industrial wiring
- Service, maintain and repair of domestic appliances
- With an added training in the specified field can become Audio/Radio/ TV Mechanic



Scan the QR Code to view the video for this exercise

Safety rules - Safety signs - Hazards

Objectives: At the end of this lesson you shall be able to

- explain the necessity of adopting the safety rules
- list the safety rules to be followed by the electrician
- explain how to treat a person for electric shock/injury.

Necessity of safety rules: Safety consciousness is one of the essential attitudes required for any job. A skilled electrician always should strive to form safe working habits. Safe working habits always save men, money and material. Unsafe working habits always end up in loss of production and profits, personal injury and even death. The safety hints given below should be followed by Electrician to avoid accidents and electrical shocks as his job involves a lot of occupational hazards.

The listed safety rules should be learnt, remembered and practised by every electrician. Here a electrician should remember the famous proverb, **“Electricity is a good servant but a bad master”**.

Safety rules

- Only qualified persons should do electrical work.
- Do not work on live circuits;
- Use wooden or PVC insulated handle screwdrivers when working on electrical circuits.
- When soldering, place the hot soldering irons in their stand.
- Replace or remove fuses only after switching off the circuit switches.
- Use extension cords with lamp guards to protect lamps against breakage and to avoid combustible material coming in contact with hot bulbs.
- Use accessories like sockets, plugs, switches and appliances only when they are in good condition and be sure they have the mark of BIS (ISI). Necessity of using BIS(ISI) marked accessories is explained under standardisation.
- Stand on rubber mats while working/operating switch panels, control gears etc.
- Position the ladder, on firm ground.
- Always use safety belts while working on poles or high rise points.
- Never place your hands on any moving part of rotating machine.
- Only after identifying the procedure of operation, operate any machine or apparatus.
- Use always earth connection for all electrical appliances along with 3-pin sockets and plugs.

- While working on dead circuits remove the fuse grips; keep them under safe custody and also display ‘Men on line’ board on the switchboard.
- Do not connect earthing to the water pipe lines.
- Discharge static voltage in HV lines/equipment and capacitors before working on them.

Safety practice - first aid

Electric shock

We are aware that the prime reasons for severity of shock are the magnitude of current and duration of contact. In addition, the other factors contribute to the severity of shock are:

- age of person
- body resistance
- not wearing insulating footwear or wearing wet footwear
- Weather condition
- Wet or dry floor
- Mains voltage etc.

If assistance is close at hand, send for medical aid, then carry on with emergency treatment.

If you are alone, proceed with the treatment immediately.

Make sure the victim is not in contact with the supply.

Effects of electric shock

The effect of current at very low levels may only be an unpleasant tingling sensation, but this itself may be sufficient to cause some persons to lose their balance and fall.

At higher levels of current the person receiving a shock may be thrown off his feet and will experience severe pain and possibly minor burns at the point of contact.

At an excessive shock can also cause burning of the skin at the point of contact.

Treatment of electric shock

Prompt treatment is essential.

Check for the victim’s natural breathing and consciousness. Take steps to apply respiratory resuscitation if the victim is unconscious and not breathing.

In the case of burns/injury in the back, follow Nelson's method

In case the mouth is closed tightly, use Schafer's or Holger-Nelson method.

Treatment for electrical burns

A person receiving an electric shock may also sustain burns when the current passes through the body.

Do not waste time by rendering first aid to the victim until breathing has been restored and the patient can breathe normally unaided.

Burns are very painful. If a large area of the body is burnt, do not give treatment, except to exclude the air, eg. by covering with clean paper or a clean cloth, soaked in clean water. this relieves the pain.

Severe bleeding

Any wound which is bleeding profusely, especially in the wrist, hand or fingers must be considered serious and must receive professional attention.

Immediate action

Always in cases of severe bleeding

- make the patient to lie down and rest
- if possible, raise the injured part above the level of the body (Fig 1)
- apply pressure to the wound
- call for medical assistance

To control severe bleeding

Squeeze together the sides of the wound. Apply pressure as long as it is necessary to stop the bleeding. When the bleeding has stopped, put a dressing over the wound and cover it with a pad of soft material. (Fig 2)

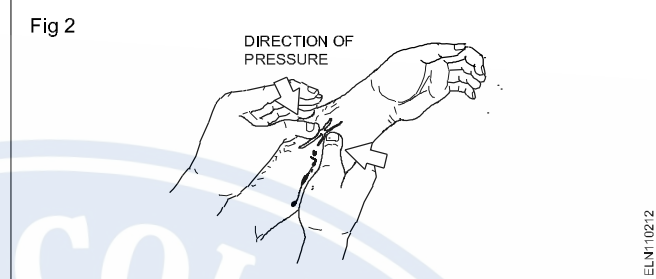
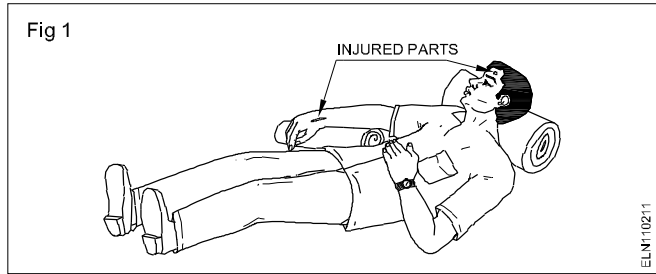

For an abdominal wound which may be caused by falling on a sharp tool, keep the patient bending over the wound to stop internal bleeding.

Large wound

Apply a clean pad and bandage firmly in place. If bleeding is very severe apply more than one dressing. (Fig 3)

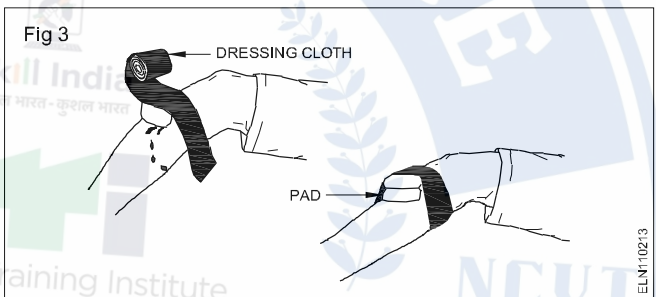

Safety practice - Safety signs

Objectives: At the end of this lesson you shall be able to

- state the responsibilities of employer and employees
- state the safety attitude and list the four basic categories of safety signs.

Responsibilities

Safety doesn't just happen - it has to be organised and achieved like the work-process of which it forms a part. The law states that both an employer and his employees have a responsibility in this behalf.

Employer's responsibilities

The effort a firm puts into planning and organising work, training people, engaging skilled and competent workers, maintaining plant and equipment, and checking, inspecting and keeping records - all of this contributes to the safety in the workplace.

The employer will be responsible for the equipment provided, the working conditions, what the employees are asked to do, and the training given.

Employee's responsibilities

You will be responsible for the way you use the equipment, how you do your job, the use you make of your training, and your general attitude to safety.

A great deal is done by employers and other people to make your working life safer; but always remember you are responsible for your own actions and the effect they have on others. You must not take that responsibility lightly.

Rules and procedure at work

What you must do, by law, is often included in the various rules and procedures laid down by your employer. They may be written down, but more often than not, are just the way a firm does things - you will learn these from other workers as you do your job.

They may govern the issue and use of tools, protective clothing and equipment, reporting procedures, emergency drills, access to restricted areas, and many other matters. Such rules are essential; they contribute to the efficiency and safety of the job.

Safety signs

As you go about your work on a construction site you will see a variety of signs and notices. Some of these will be familiar to you - a 'no smoking' sign for example; others

you may not have seen before. It is up to you to learn what they mean - and to take notice of them. They warn of the possible danger, and must not be ignored.

Safety signs fall into four separate categories. These can be recognised by their shape and colour. Sometimes they may be just a symbol; other signs may include letters or figures and provide extra information such as the clearance height of an obstacle or the safe working load of a crane.

The four basic categories of signs are as follows:

- prohibition signs (Fig 1 & Fig 5)
- mandatory signs (Fig 2 & Fig 6)
- warning signs (Fig 3 & Fig 7)
- information signs (Fig 4)

Prohibition signs

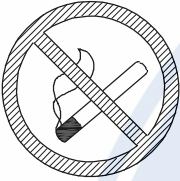
	SHAPE	Circular.
	COLOUR	Red border and cross bar. Black symbol on white background.
	MEANING	Shows it must not be done.
	Example	No smoking.



Mandatory signs

	SHAPE	Circular.
	COLOUR	White symbol on blue background
	MEANING	Shows what must be done.
	Example	Wear hand protection.

Warning signs

	SHAPE	Triangular.
	COLOUR	Yellow background with black border and symbol.
	MEANING	Warns of hazard or danger.
	Example	Caution, risk of electric shock.

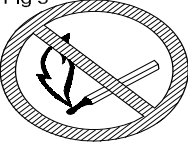
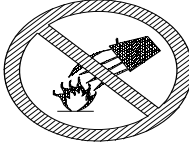
Prohibition signs

		
SMOKING AND NAKED FLAMES PROHIBITED	DO NOT EXTINGUISH WITH WATER	PEDESTRIANS PROHIBITED



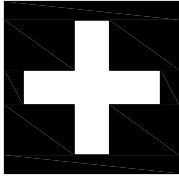







Information signs

	SHAPE	Square or oblong.
	COLOUR	White symbols on green background.
	MEANING	Indicates or gives information of safety provision.
	Example	First aid point.

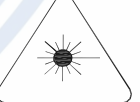
Mandatory signs

		
WEAR HEAD PROTECTION	WEAR EYE PROTECTION	WEAR HEARING PROTECTION
		
WEAR FOOT PROTECTION	WEAR HAND PROTECTION	WEAR RESPIRATOR
		
WEAR SAFETY HARNESS/BELT	USE ADJUSTABLE GUARD	WASH HAND
MANDATORY SIGNS		

Warning signs

		
RISK OF FIRE	RISK OF ELECTRIC SHOCK	TOXIC HAZARD
		
CORROSIVE SUBSTANCES	RISK OF IONIZING RADIATION	LASER BEAM
		
RISK OF EXPLOSION	OVERHEAD (FIXED) HAZARD	GENERAL WARNING RISK OF DANGER
		
OVERHEAD LOAD	FRAGILE ROOF WARNING SIGNS	FORK LIFT TRUCK

Fire - Types - Extinguishers

Objectives: At the end of this lesson you shall be able to

- state the effects of a fire break out and causes of fire in a workshop
- distinguish the different types of fire extinguishers
- state the classification of fires and basic ways for extinguishing the fire
- determine the correct type of fire extinguisher to be used based on the class of fire
- describe the general procedure to be adopted in the event of fire
- state the method of operation of fire extinguisher and extinguishing of fire.



Scan the QR Code to view the video for this exercise

Fire : Is it possible to prevent fire? Yes, fire can be prevented by eliminating anyone of the three factors that cause fire.

The following are the three factors that must be present in combination for a fire to continue to burn. (Fig 1)

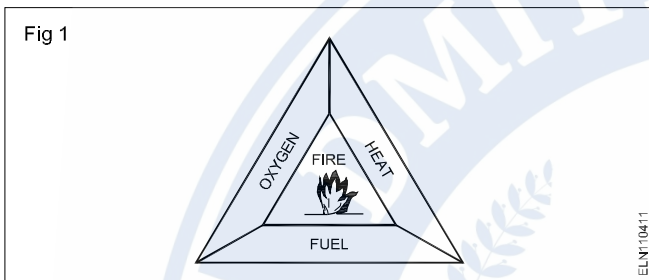

Fuel: Any substance, liquid, solid or gas will burn, if there is oxygen and high enough temperatures.

Heat: Every fuel will begin to burn at a certain temperature. It varies and depends on the fuel. Solids and liquids give off vapour when heated, and it is this vapour which ignites.

Oxygen: Usually exists in sufficient quantity in air to keep a fire burning.

Extinguishing of fire: Isolating or removing any of these factors from the combination will extinguish the fire. There are three basic ways of achieving this.

- **Starving** the fire of fuel removes this element.
- **Smothering** - ie. isolate the fire from the supply of oxygen by blanketing it with foam, sand etc.
- **Cooling** - use water to lower the temperature.

Removing any one of these factors will extinguish the fire.

Classification of fires: Fires are classified into four types in terms of the nature of fuel.

Different types of fires (Fig 2, Fig 3 Fig 4 & Fig 5) have to be dealt with in different ways and with different extinguishing agents.

Fire Classification and Fuel	Extinguishing Method
<p>Fig 2</p> <p>CLASS 'A' FIRE</p> <p>WOOD CLOTH PAPER</p>	<p>Most effective ie., cooling with water. Jets of water should be sprayed on the base of the fire and then gradually upwards.</p>
<p>Fig 3</p> <p>CLASS 'B' FIRE</p> <p>FLAMMABLE LIQUIDS AND LIQUIFIABLE SOLIDS</p>	<p>Should be smothered :- The aim is to cover the entire surface of the burning liquid. This has the effect of cutting off the supply of oxygen to the fire.</p> <p>Water should never be used on burning liquids.</p> <p>Foam, dry powder or CO₂ may be used on this type of fire.</p>

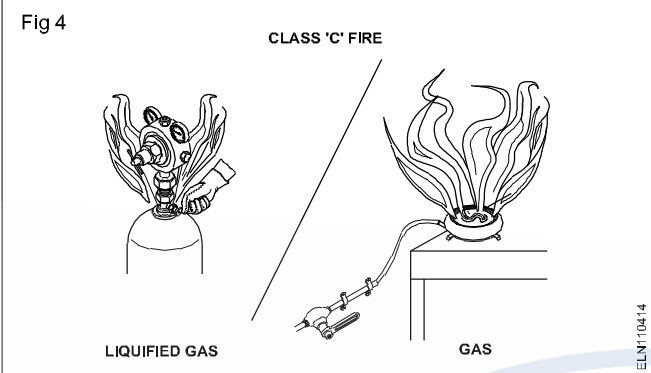
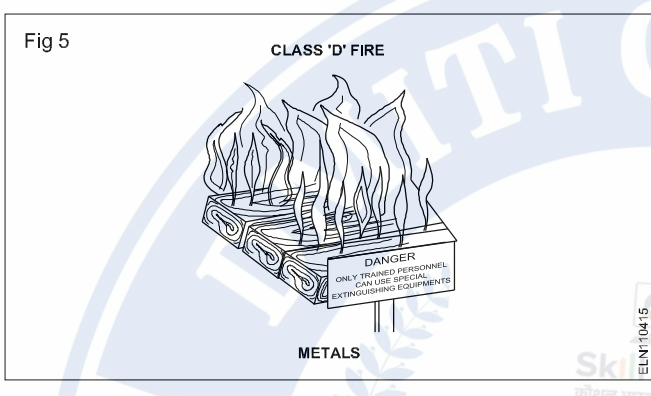
Fire Classification and Fuel	Extinguishing Method
<p>Fig 4</p>  <p>LIQUEFIED GAS</p> <p>CLASS 'C' FIRE</p> <p>GAS</p> <p>ELN110414</p>	<p>Extreme caution is necessary in dealing with liquefied gases. There is a risk of explosion and sudden outbreak of fire in the entire vicinity. If an appliance fed from a cylinder catches fire - shut off the supply of gas. The safest course is to raise an alarm and leave the fire to be dealt with by trained personnel.</p> <p>Dry powder extinguishers are used on this type of fire.</p>
<p>Fig 5</p>  <p>CLASS 'D' FIRE</p> <p>DANGER ONLY TRAINED PERSONNEL CAN USE SPECIAL EXTINGUISHING EQUIPMENTS</p> <p>METALS</p> <p>ELN110415</p>	<p>Special powders have now been developed which are capable of controlling and/or extinguishing this type of fire.</p> <p>The standard range of fire extinguishing agents is inadequate or dangerous when dealing with metal fires.</p> <p>Fire on electrical equipment.</p> <p>Halon, Carbon dioxide, dry powder and vapourising liquid (CTC) extinguishers can be used to deal with fires in electrical equipment. Foam or liquid (eg. water) extinguishers must not be used on electrical equipment under any circumstances.</p>

Types of Fire Extinguisher

Many types of fire extinguishers are available with different extinguishing 'agents' to deal with different classes of fires. (Fig 6)

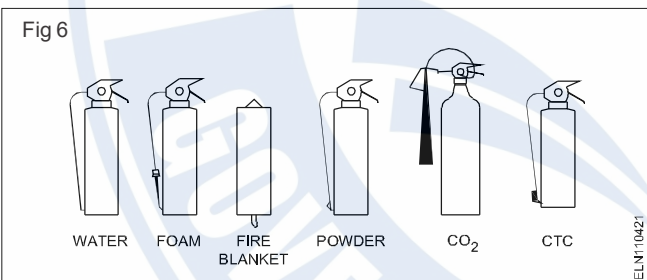

Water-filled extinguishers: There are two methods of operation. (Fig 7)

- Gas cartridge type
- Stored pressure type

With both methods of operation the discharge can be interrupted as required, conserving the contents and preventing unnecessary water damage.

Foam extinguishers (Fig 8): These may be of stored pressure or gas cartridge types.

Most suitable for

- flammable liquid fires
- running liquid fires

Must not be used on fires where electrical equipment is involved.

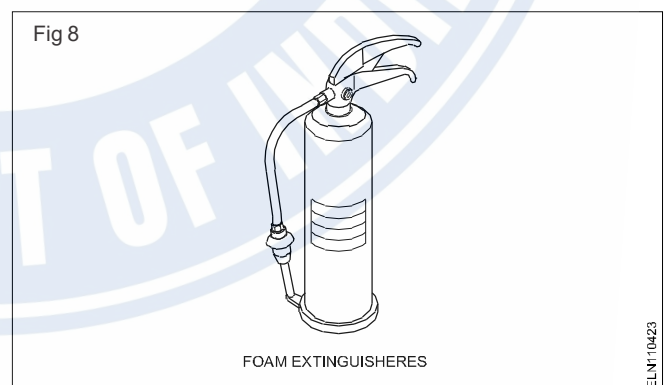
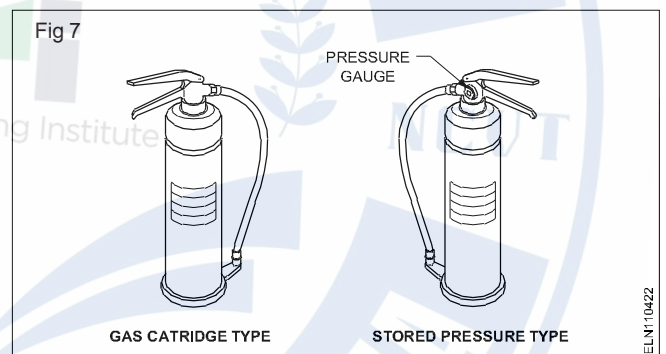

Dry powder extinguishers (Fig 9): Extinguishers fitted with dry powder may be of the gas cartridge or stored pressure type. Appearance and method of operation is the same as that of the water-filled one. The main distinguishing feature is the fork shaped nozzle. Powders have been developed to deal with class D fires.

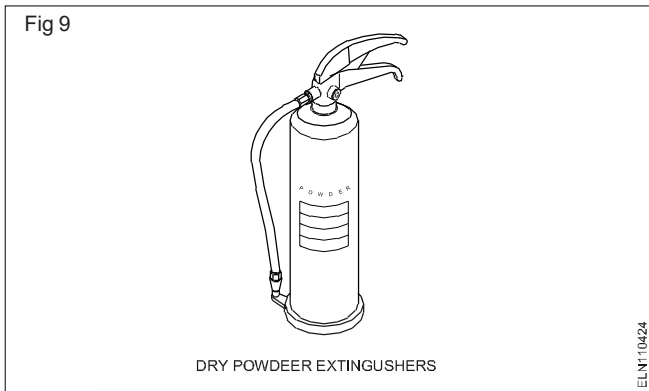

Carbon dioxide (CO₂): This type is easily distinguished by the distinctively shaped discharge horn. (Fig 10).

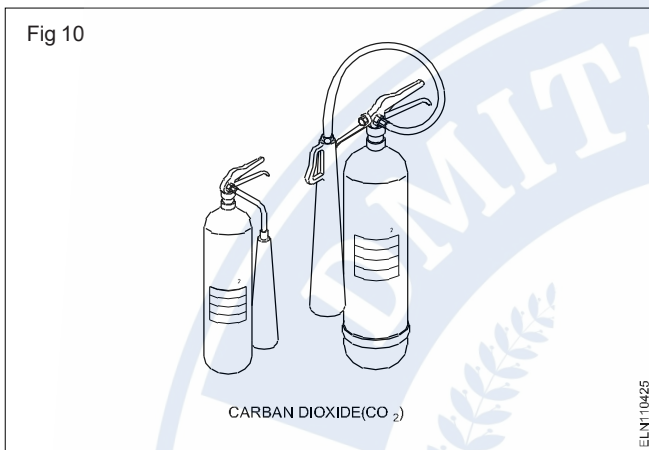

Suitable for Class B fires. Best suited where contamination by deposits must be avoided. Not generally effective in open air.

Always check the operating instructions on the container before use. Available with different gadgets of operation such as - plunger, lever, trigger etc.

The general procedure in the event of a fire:

- Raise an alarm.
- Turn off all machinery and power (gas and electricity).
- Close the doors and windows, but do not lock or bolt them. This will limit the oxygen fed to the fire and prevent its spreading.
- Try to deal with the fire if you can do so safely. Do not risk getting trapped.

- Anybody not involved in fighting the fire should leave calmly using the emergency exits and go to the designated assembly point.
- Analyze and identify the type of fire. Refer Table1.

Table 1

Class 'A'	Wood, paper, cloth, solid material
Class 'B'	Oil based fire (grease, gasoline, oil) liquifiable gases
Class 'C'	Gas and liquifiable gases
Class 'D'	Metals and electrical equipment

Fire extinguishers are manufactured for use from the distance.

Caution

- While putting off fire, the fire may flare up
- Do not be panick belong as it put off promptly.
- If the fire doesn't respond well after you have used up the fire extinguisher move away yourself away from the fire point.
- Do not attempt to put out a fire where it is emitting toxic smoke leave it for the professionals.
- Remember that your life is more important than property. So don't place yourself or others at risk.

In order to remember the simple operation of the extinguisher. Remember P.A.S.S. This will help you to use the fire extinguisher.

P for Pull

A for Aim

S for Squeeze

S for Sweep

Rescue operation - First aid treatment - Artificial respiration



Scan the QR Code to view the video for this exercise

- Objectives:** At the end of this lesson you shall be able to
- explain how to rescue a person who is in contact with a live wire.
 - state the first aid and its key aims.
 - explain ABC of the first aid.
 - brief how to give first aid treatment for a victim.
 - explain how to treat a person affected due to electric shock/injury.

The severity of an electric shock will depend on the level of current which passes through the body and the length of time of contact. Do not delay, act at once. Make sure that the electric current has been disconnected. If the victim is still in contact with the supply - break the contact either by switching off or by removing the plug or pulling the cable free.

If not, stand on some insulating material such as dry wood, rubber or plastic or newspaper and then pull his shirt sleeves. However, you have to insulate yourself and break the contact by pushing or pulling the person free. (Figs1 & 2)

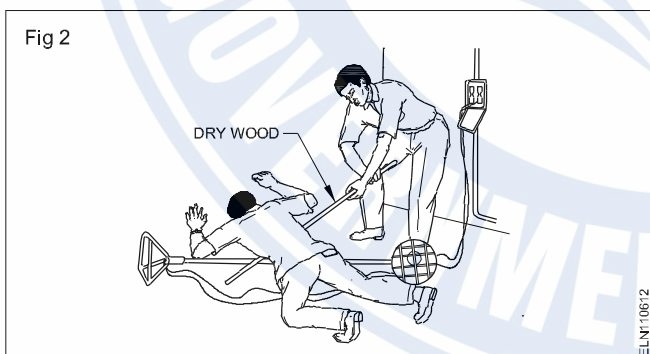

In any case avoid direct contact with the victim. Wrap your hands in dry material if rubber gloves are not available.

If you remain un-insulated, do not touch the victim with your bare hands until the circuit is made dead or he is moved away from the equipment.

If the victim is at a height, efforts must be taken to prevent him from falling or to make him fall safe.

Electric burns on the victim may not cover a big area but may be deep seated. All you can do is to cover the area

with a clean, sterile dressing and treat for shock. Get expert help as quickly as possible.

If the casualty is unconscious but is breathing, loosen the clothing about the neck, chest and waist (Fig 3) and place the casualty in the recovery position.



Keep a constant check on the breathing and pulse rate.

Keep the casualty warm and comfortable in the recover position. Send for help.(Fig 4)

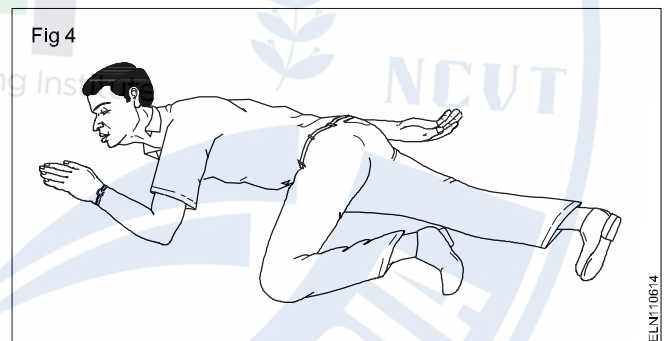

Do not give an unconscious person anything to eat or drink.
Do not leave an unconscious person unattended.

If the casualty is not breathing - **Act at once to resuscitate the victim** - do not waste time.

Basic first-aid treatment

First aid is defined as the immediate care and support given to an acutely injured or ill person, primarily to save life, prevent further deterioration or injury, plan to shift the victim to safer place, provide best possible comfort and finally help them to reach the medical centre/ hospital through all available means. It is an immediate life-saving procedure using all resources available within reach.

The key aims of first aid can be summarized in three key points:

- **Preserve life:** If the patient was breathing, a first aider would normally then place them in the recovery position, with the patient leant over on their side, which also has the effect of clearing the tongue from the pharynx. It also avoids a common cause of death in unconscious patients, which is choking on regurgitated stomach contents.
- **Prevent further harm:** Also sometimes called prevent the condition from worsening, or danger of further injury.
- **Promote recovery:** First aid also involves trying to start the recovery process from the illness or injury, and in some cases might involve completing a treatment, such as in the case of applying a plaster to a small wound.

Training

Basic principles, such as knowing to use an adhesive bandage or applying direct pressure on a bleed, are often acquired passively through life experiences. However, to provide effective, life-saving first aid interventions requires instruction and practical training.

ABC of first aid

ABC stands for **A**irway, **B**reathing and **C**irculation.

- **Airway:** Attention must first be brought to the airway to ensure it is clear. Obstruction (choking) is a life-threatening emergency.
- **Breathing:** Breathing if stops, the victim may die soon. Hence means of providing support for breathing is an important next steps. There are several methods practiced in first aid.
- **Circulation:** Blood circulation is vital to keep person alive. The first aiders now trained to go straight to chest compressions through CPR methods.

Not to get panic

Panic is one emotion that can make the situation more worse. People often make mistake because they get panic.

Call medical emergencies

If the situation demands, quickly call for medical assistance. Prompt approach may save the life.

Surroundings play vital role

Different surroundings require different approach. Hence first aider should study the surrounding carefully.

Do no harm

Most often over enthusiastically practiced first aid viz. administering water when the victim is unconscious, wiping clotted blood (which acts as plug to reduce bleeding), correcting fractures, mishandling injured parts etc., would leads to more complication.

Reassurance

Reassure the victim by speaking encouragingly with him.

Stop the bleeding

If the victim is bleeding, try to stop the bleeding by applying pressure over the injured part.

Golden hours

India have best of technology made available in hospitals to treat devastating medical problem viz. head injury, multiple trauma, heart attack, strokes etc, but patients often do poorly because they don't gain access to that technology in time.

The risk of dying from these conditions, is greatest in the first 30 minutes, often instantly. This period is referred to as **Golden period**.

Maintain the hygiene

Most important, the first aider need to wash hands and dry before giving any first aid treatment to the patient.

CPR (Cardio-Pulmonary Resuscitation) can be life-sustaining

CPR can be life sustaining. If one is trained in PR and the person is suffering from choking or finds difficulty in breathing, immediately begin CPR.

Call emergency service

The emergency number varies - 100 for Police & Fire, 108 for Ambulance.

Report your location

The first thing the emergency dispatcher will ask is where you are located, so the emergency services can get there as quickly as possible. Give the exact street address, if you're not sure of the exact address, give approximate information.

Give the dispatcher your phone number

This information is also imperative for the dispatcher to have, so that he or she is able to call back if necessary.

Important guideline for first aiders

Evaluate the situation

Are there things that might put the first aider at risk. When faced with accidents like fire, toxic smoke, gasses, an unstable building, live electrical wires or other dangerous scenario, the first aider should be very careful not to rush into a situation, which may prove to be fatal.

Remember A-B-Cs

The ABCs of first aid refer to the three critical things the first aiders need to look for.

- **Airway** - Does the person have an unobstructed airway?
- **Breathing** - Is the person breathing?
- **Circulation** - Does the person show a pulse at major pulse points (wrist, carotid artery, groin)

Call emergency services : Call for help or tell someone else to call for help as soon as possible. If alone at the accident scene, try to establish breathing before calling for help, and do not leave the victim alone unattended.

Determine responsiveness

If a person is unconscious, try to rouse them by gently shaking and speaking to them.

If the person remains unresponsive, carefully roll them on the side (recovery position) and open his airway.

- Keep head and neck aligned.
- Carefully roll them onto their back while holding his head.
- Open the airway by lifting the chin (Fig 1).

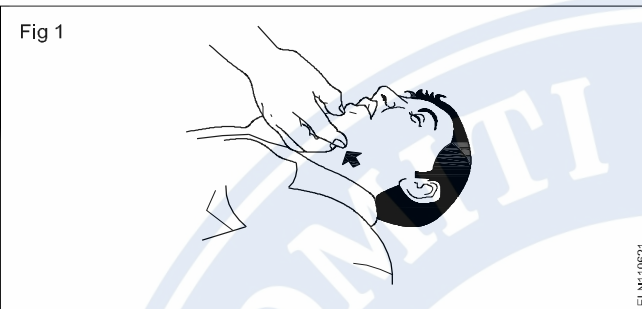

Look, listen and feel for signs of breathing

Look for the victim's chest to raise and fall, listen for sounds of breathing.

- **Treat shock:** Shock may causes loss of blood flow from the body, frequently follows physical and occasionally psychological trauma.
- **Choking victim:** Choking can cause death or permanent brain damage within minutes.

Stay with the victim until help arrives

Try to be a calming presence for the victim until assistance can arrive.

Unconsciousness (COMA)

Unconscious also referred as Coma, is a serious life threatening condition, when a person lie totally senseless and do not respond to calls, external stimulus. But the basic heart, breathing, blood circulation may be still intact, or they may also be failing. If unattended it may lead to death.

First aid

- Call EMERGENCY number.
- Check the person's airway, breathing, and pulse frequently. If necessary, begin rescue breathing and CPR.
- If the person is breathing and lying on the back and after ruling out spinal injury, carefully roll the person onto the side, preferably left side.

Bend the top leg so both hip and knee are at right angles. Gently tilt the head back to keep the airway open (Fig 2). If breathing or pulse stops at any time, roll the person on to his back and begin CPR.

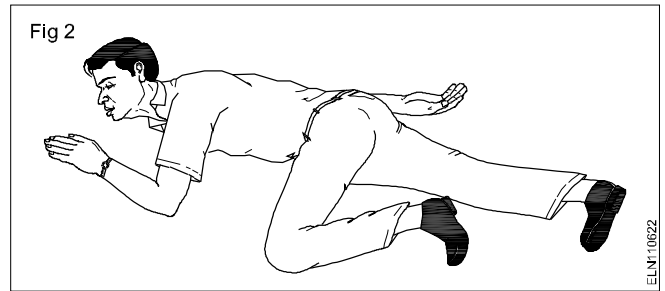

- If there is a spinal injury, the victims position may have to be carefully assessed. If the person vomits, roll the entire body at one time to the side. Support the neck and back to keep the head and body in the same position while you roll.
- Keep the person warm until medical help arrives.
- If you see a person fainting, try to prevent a fall. Lay the person flat on the floor and raise the level of feet above and support.

First aid

Keep the patient warm and at mental rest. Assure of good air circulation and comfort. Call for help to shift the patient to safer place/ hospital.

- **Warmth:** Keep the victim warm but do not allow them to get overheated.
- **Air:** Maintain careful eye on the victim's airway.
- **Rest:** Keep the victim still and preferably sitting or lying down. If the victim is very giddy, lay them down with there legs raised to ensure that maximum blood and therefore maximum oxygen is sent to the brain.

Treatment of electric shock

Prompt treatment is essential

If assistance is close at hand, send for medical aid, then carry on with emergency treatment.

If you are alone, proceed with treatment at once.

Switch off the supply, if this can be done without undue delay. Otherwise, remove the victim from contact with the live conductor, using dry non-conducting materials such as a wooden bar, rope, a scarf, the victim's coat-tails, any dry article of clothing, a belt, rolled-up newspaper, non-metallic hose, PVC tubing, bakelised paper, tube etc. (Fig 3)

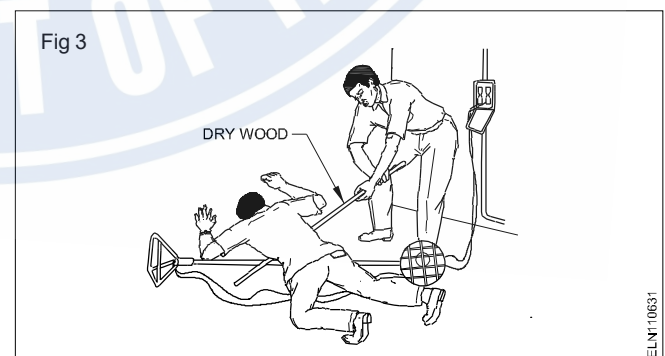

Avoid direct contact with the victim. Wrap your hands in dry material if rubber gloves are not available.

Disposal of waste material

- Objectives:** At the end of this lesson you shall be able to
- state about the waste material
 - state the types of waste material and source of waste
 - list out the waste material in workshop
 - explain the methods of disposal of waste material.



Scan the QR Code to view the video for this exercise

Waste

Waste are unwanted or unusable materials. Waste is any substance which is discarded after primary use, or it is worthless, defective and of no use.

Waste can be broadly classified as follows

- a Rural waste
- b Urban waste
 - i Solid waste
 - ii Liquid waste

a Rural waste

Rural waste is the waste from agricultural and dairy forms.

b Urban waste

It is the waste from house hold articles or from industries within municipal limit

It can be again classified into two types.

i Solid waste

Solid waste is the material is hard (from industries) such as newspaper, cans, bottles, broken glass, plastics container, polythene bags etc.

ii Liquid waste

It is the water based waste which is produced by the main activation sources of waste.

Sources of waste

i Industrial waste

It contains solid as well as liquid waste and is formed by the processing of various materials.

ii Domestic waste

It includes all rubbish, garbage, dust, sewage waste etc. It contains combustible and non-combustible materials. When these waste disposal off openly cause various harmful effects.

iii Agricultural waste

It includes the waste produced from the crops and cattle etc. Open disposal of thin waste create problems for health of man and other animals.

iv Ash produced by interval power plants.

v Hospital waste is most harmful waste off contains micro organisms which cause both communicable and non-communicable diseases.

List out the waste material in workshop (Fig 1)

- Oily waste such as lubricating oil, coolant etc.
- Cotton waste.
- Metal chips of different materials.
- Electrical waste such as used and damaged accessories, wires, cables, pipes etc.

Methods of disposal of waste (Fig 2)

Disposal process : This is the final step of the waste management. From this disposal point or site the materials are selected steps as

- Recycling
- Composing
- Landfill
- Incineration

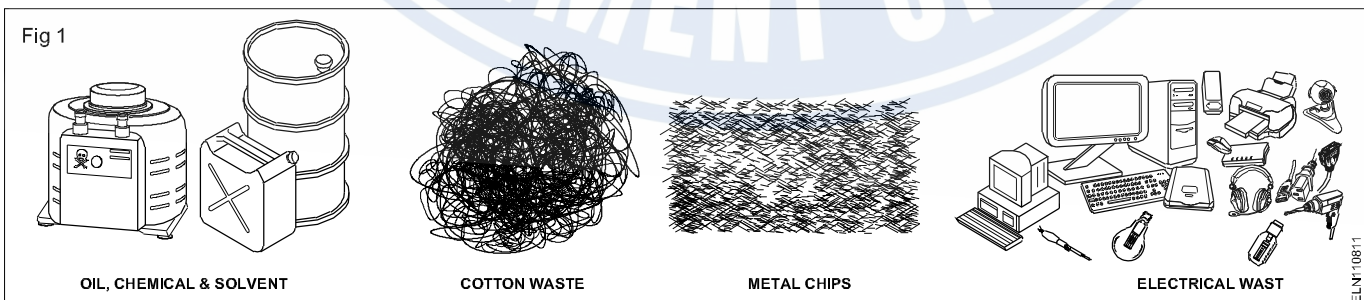

- Waste compaction
- Reuse
- Animal Feed
- Fire Wood

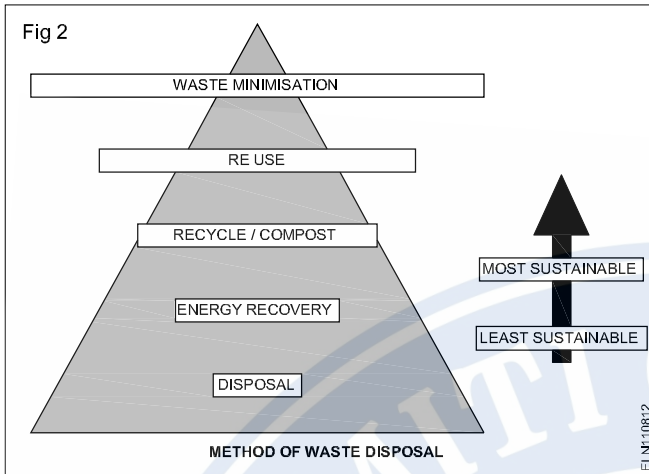

Recycling

Recycling is one of the most well known method of managing waste. It is not expensive and can be easily done by you. If you carry out recycling, you will save a lot of energy, resources and thereby reduce pollution.

Composting

This is a natural process that is completely free of any hazardous by-products. This process involves breaking down the material into organic compounds that can be used as manure.

Landfill

In this process, the waste cannot be reused or recycled separated out and spread as a thin layer in some low-lying areas across the city.

Incineration (Fig 3)

It is the process of controlled combustion of garbage to reduce it to incombustible matter, ash, waste gas and heat. It is treated and released into the environment (Fig 3). This reduced 90% volume of waste, some time the heat generated used to produce electric power.

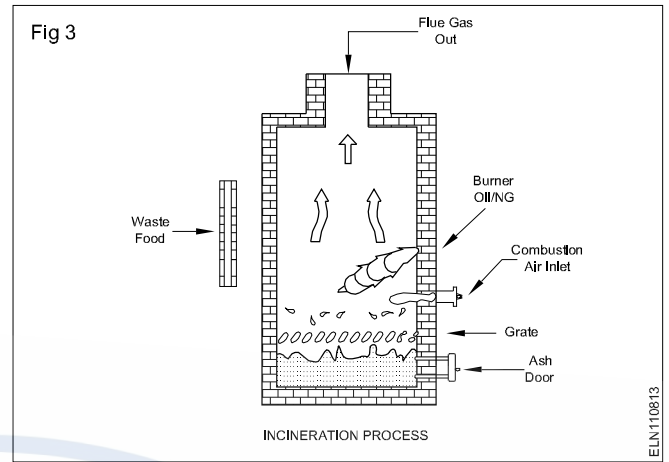

Waste compaction

The waste materials such as cans and plastic bottles compact into blocks and send for recycling. This process need space, thus making transportation and positioning difficult.

Reuse

The amount of waste disposal can be reduced by carefully considering the exact throwing away. Before discarding the item think for the possibility to wash and reuse them.

Animal Feed:

Vegetable peel and food scraps can be retained to feed small animals such as lamsters rabbit etc. Large meat bones will be greatly reused by feeding dog.

Fire Wood:

A small amount of waste disposal can be reused when it comes to refurbishing have or replacing furniture. before discarding the furniture, cut it into more meaningful process and use as fire wood.

Personal Protective Equipment (PPE)

Objectives: At the end of this lesson you shall be able to

- state about Personal Protective Equipment (PPE) and its purpose
- explain the occupational health safety, hygien
- explain occupational hazards
- list the most common type of personal protective equipment for hazards



Scan the QR Code to view the video for this exercise

Personal Protective Equipment (PPE)

The Devices, equipment, or clothing used or worn by the employees, as a last resort, to protect against hazards in the workplace. The primary approach in any safety effort is that the hazard to the workmen should be eliminated or controlled by engineering methods rather than protecting the workmen through the use of personal protective equipment (PPE).

In situations where it is not possible to introduce any effective engineering methods for controlling hazards, the workman shall use appropriate types of PPE.

The Factories Act, 1948 and several other labour legislations 1996 have provisions for effective use of appropriate types of PPE. Use of PPE is an important.

Ways to ensure workplace safety and use personal protective equipment (PPE) effectively.

- Workers to get up-to-date safety information from the regulatory agencies that oversees workplace safety in their specific area.
- To use all available text resources that may be in work area and for applicable safety information on how to use PPE best.
- When it comes to the most common types of personal protective equipment, like goggles, gloves or bodysuits, these items are much less effective if they are not worn at all times, or whenever a specific danger exists in a work process. Using PPE consistently will help to avoid some common kinds of industrial accidents.
- Personal protective equipment is not always enough to protect workers against workplace dangers. Knowing more about the overall context of your work activity can help to fully protect from anything that might threaten health and safety on the job.
- Inspection of gear thoroughly to make sure that it has the standard of quality and adequately protect the user should be continuously carried out.

Categories of PPEs

Depending upon the nature of hazard, the PPE is broadly divided into the following two categories:

- 1 **Non-respiratory:** Those used for protection against injury from outside the body, i.e. for protecting the head, eye, face, hand, arm, foot, leg and other body parts
- 2 **Respiratory:** Those used for protection from harm due to inhalation of contaminated air.

The guidelines on 'Personal Protective Equipment' is issued to facilitate the plant management in maintaining an effective programme with respect to protection of persons against hazards, which cannot be eliminated or controlled by engineering methods listed in table1.

Table1

No.	Title
PPE1	Helmet
PPE2	Safety footwear
PPE3	Respiratory protective equipment
PPE4	Arms and hands protection
PPE5	Eyes and face protection
PPE6	Protective clothing and coverall
PPE7	Ears protection
PPE8	Safety belt and harnesses

Personal protective equipments and their uses and hazards are as follows

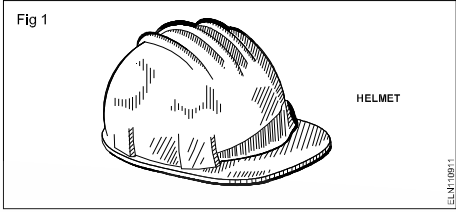
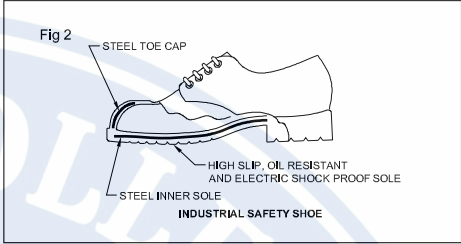
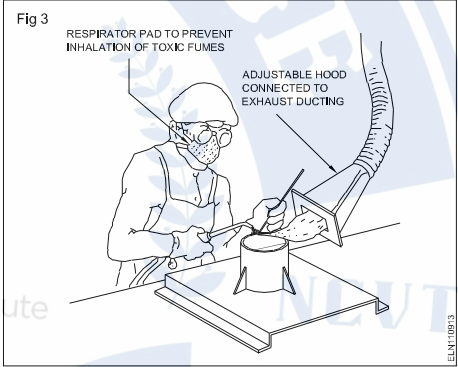
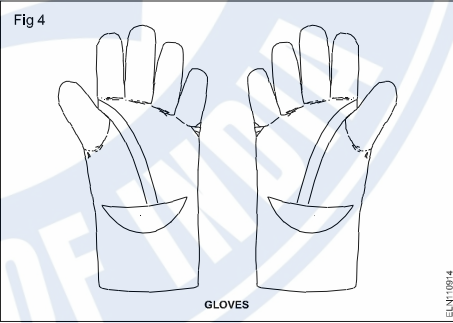
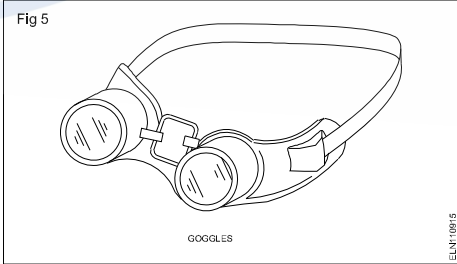
Types of protection	Hazards	PPE to be used
Head Protection (Fig 1)	<ol style="list-style-type: none"> 1. Falling objects 2. Striking against objects 3. Spatter 	 <p>Fig 1</p> <p>HELMET</p>
Foot protection (Fig 2)	<ol style="list-style-type: none"> 1. Hot spatter 2. Falling objects 3. Working wet area 	 <p>Fig 2</p> <p>STEEL TOE CAP</p> <p>HIGH SLIP, OIL RESISTANT AND ELECTRIC SHOCK PROOF SOLE</p> <p>STEEL INNER SOLE</p> <p>INDUSTRIAL SAFETY SHOE</p> <p>leather leg guards</p>
Nose (Fig 3)	<ol style="list-style-type: none"> 1. Dust particles 2. Fumes/ gases/ vapours 	 <p>Fig 3</p> <p>RESPIRATOR PAD TO PREVENT INHALATION OF TOXIC FUMES</p> <p>ADJUSTABLE HOOD CONNECTED TO EXHAUST DUCTING</p>
Hand protecion (Fig 4)	<ol style="list-style-type: none"> 1. Heat burn due to direct contact 2. Blows sparks moderate heat 3. Electric shock 	<p>Hand Gloves</p>  <p>Fig 4</p> <p>GLOVES</p>
Eye protection (Fig 5)	<ol style="list-style-type: none"> 1. Flying dust particles 2. UV rays, IR rays heat and High amount of visible radiation 	<p>Googles</p>  <p>Fig 5</p> <p>GOOGLES</p>

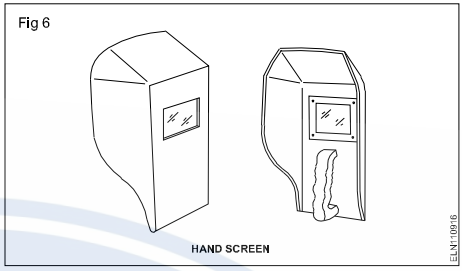
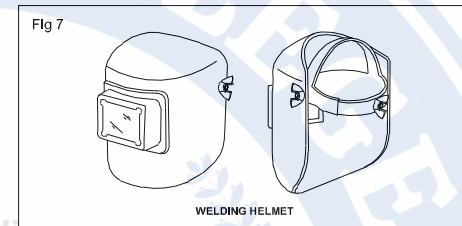
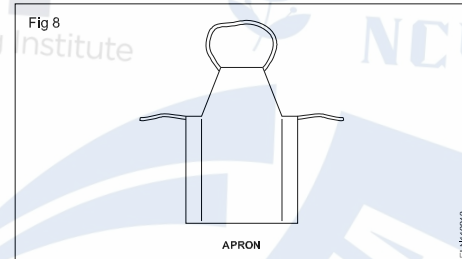
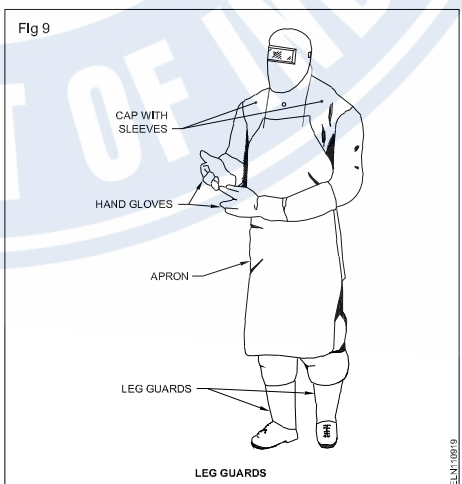
Types of protection	Hazards	PPE to be used
Face Protection (Fig 6, Fig 7)	1. Spark generated during Welding, grinding 2. Welding spatter striking 3. Face protection from UV rays	<p style="text-align: center;">Face Shield Head Shield with or without Ear Muff Helmets with screen for welders</p> <div style="text-align: center;">  <p>Fig 6</p> <p>HAND SCREEN</p> </div>
Ear protection (Fig 7)	1. High noise level	<p style="text-align: center;">Head shield with Ear muff</p> <div style="text-align: center;">  <p>Fig 7</p> <p>WELDING HELMET</p> </div>
Body protection (Fig 8, Fig 9)	1. Hot particles	<p style="text-align: center;">Bodyguard</p> <div style="text-align: center;">  <p>Fig 8</p> <p>APRON</p> </div> <div style="text-align: center;">  <p>Fig 9</p> <p>CAP WITH SLEEVES</p> <p>HAND GLOVES</p> <p>APRON</p> <p>LEG GUARDS</p> <p>LEG GUARDS</p> </div>

Proper use of PPEs

Having selected the proper type of PPE, it is essential that the workman wears it. Often the workman avoids using PPE.

Occupational health hazard and safety

Safety

Safety means freedom or protection from harm, danger, hazard, risk, accident, injury or damage.

Occupational health and safety

- Occupational health and safety is concerned with protecting the safety, health and welfare of people engaged in work or employment.
- The goal is to provide a safe work environment and to prevent hazards.
- It may also protect co-workers, family members, employers, customers, suppliers, nearby communities, and other members of the public who are affected by the workplace environment.

Need of occupational health and safety

- Health and safety of the employees is an important aspect of a company's smooth and successful functioning.
- Improving employee morale
- Reducing absenteeism
- Enhancing productivity
- Minimizing potential of work-related injuries and illnesses
- Increasing the quality of manufactured products and/or rendered services.

Occupational (Industrial) hygiene

- Occupational hygiene is anticipation, recognition, evaluation and control of work place hazards (or) environmental factors (or) stresses
- Which may cause sickness, impaired health and well being (or) significant discomfort and inefficiency among workers.

Evaluation (Measurement & Assessment): Measuring or calculating the hazard by Instruments, Air sampling and Analysis, comparison with standards and taking judgement whether measured or calculated hazard is more or less than the permissible standard.

Control of workplace hazards: Measures like Engineering and Administrative controls, medical examination, use of Personal Protective Equipment (PPE), education, training and supervision

Types of occupational health hazards

- Physical Hazards
- Chemical Hazards
- Biological Hazards

- Physiological Hazards
- Mechanical Hazards
- Electrical Hazards
- Ergonomic Hazards.

1 Physical hazards

- Noise
- Heat and cold stress
- Illumination etc.,

2 Chemical hazards

- Inflammable
- Explosive

3 Biological hazards

- Bacteria
- Virus

4 Physiological

- Old age
- Sex
- Ill health
- Sickness
- Fatigue.

5 Psychological

- Wrong attitude
- Smoking
- Alcoholism
- Unskilled
- Emotional disturbances
 - violence
 - bullying
 - sexual harassment

6 Mechanical

- Unguarded machinery
- No fencing

7 Electrical

- No earthing
- Short circuit
- No fuse or cut off device etc,

8 Ergonomic

- Poor manual handling technique
- Wrong layout of machinery
- Wrong design
- Poor housekeeping

Safety Slogan

A Safety rule breaker, is an accident maker

Guidelines for cleanliness of workshop and maintenance

Objectives: At the end of this lesson you shall be able to

- state the necessity of cleaning of workshop
- list the benefits of shop floor cleaning and maintenance
- state the common cleaning procedure in workshop
- list the different methods of cleaning process
- state the concept of 5s techniques and their description
- list the benefits of 5s techniques.



Scan the QR Code to view the video for this exercise

Cleaning process

Cleaning is the process of removal of unwanted matter, contaminants or pollutants from the environment or the prevention of soiling thus it should be - GREEN clean.

‘Green-cleaning’ means the need to clean up the cleaning process and protect themselves.

Cleaning is about removing pollution, not adding to it.

Necessity of cleaning of workshop

A clean workplace ensures safety and health of employees and injuries can be prevented by taking action to ensure a clean, safe work environment.

Reasons for cleaning the workplace

- Cleaning of dry floors essentially to prevent slips and falls in the workplace.
- Disinfectants prevents the spread germs and illness, because it will stop germs in their tracks.
- Proper air filtration reduces the exposures of hazardous substances like dust and vapors.
- Cleaning of light fixtures improve lighting efficiency.
- Using green cleaning products which is safer for both employees and the environment.
- Proper disposal of waste and recyclable materials keeps work areas clean.

Benefits of a shop floor maintenance

- Productive can be improved.
- Improves operator’s efficiencies.
- Improves the support operations such as replacement moves and finished goods.
- Reduction of scrap.
- Manufacturing process can be controlled effectively.
- Reduction of downtime due to better machine and tool monitoring.
- Better control of inventory process.

Common cleaning procedure

- Before starting to clean, read the product and equipment labels and usage instructions.
- Wear recommended Personal Protective Equipment (PPE) like rubber or surgical type gloves, goggles, dust mask or respirator, earplugs etc.
- Cleaning must be performed to prevent or remove soils, contaminants or pollutants.
- Select and use less toxic products and this system is known as “**Standard Operating Procedures**” (SOPs).
- SOPs is the part of the over all operation and maintenance plan for bending.

Other different methods of cleaning are

- Sprinkling
- Spraying
- Power wash process
- Boiling under pressure
- Carbon dioxide cleaning
- Pre cleaning
- Main cleaning
- Rinsing
- Drying etc,

For improving the standardising the way to clean **Standard Operating Procedures (SOPs)** as a set of written guidelines must be provided to the cleaners which includes

- 1 Cleaning procedures
- 2 Chemical handling and tracking requirements
- 3 Communication protocols
- 4 Training and inspection programs
- 5 Reporting and record keeping procedures.

The above guidelines should be made available to all cleaning personnel and occupants.

Recommended activities for green cleaning

- Provide easily understood directions to cleaning staff in written with local languages.

- Use the appropriate technology (coarse spray, automatic chemical dispensers etc).
- Provide directory for the proper rinsing and disposal of expended or empty solution containers.
- Reduce, minimize or eliminate the need for using cleaning chemicals if possible.

5 Steps (5s) - Concept

5s is a people-oriented and practice-oriented approach. 5s expects every one to participate in it. It becomes a basic for continuous improvement in the organisation.

The terms (5s) 5 steps are

Step 1: SEIRI (Sorting out)

Step 2: SEITON (Systematic arrangement)

Step 3: SEISO (Shine cleanliness)

Step 4: SEIKTSU (Stanardization)

Step 5: SHITSURE (Self discipline)

Fig 1 shows the 5s concept wheel.

The list describes how to organize a work space for efficiency and effectiveness by identifying and storing the items used, maintaining the area and items and sustaining the new order.

Benefits of 5s

- Work place becomes clearer and better organised.
- Working in working place becomes easier.

- Reduction in cost.
- People tend to be more disciplined.
- Delay is avoided.
- Less absenteeism.
- Better use of floor space.
- Less accidents.
- High productivity with quality etc.

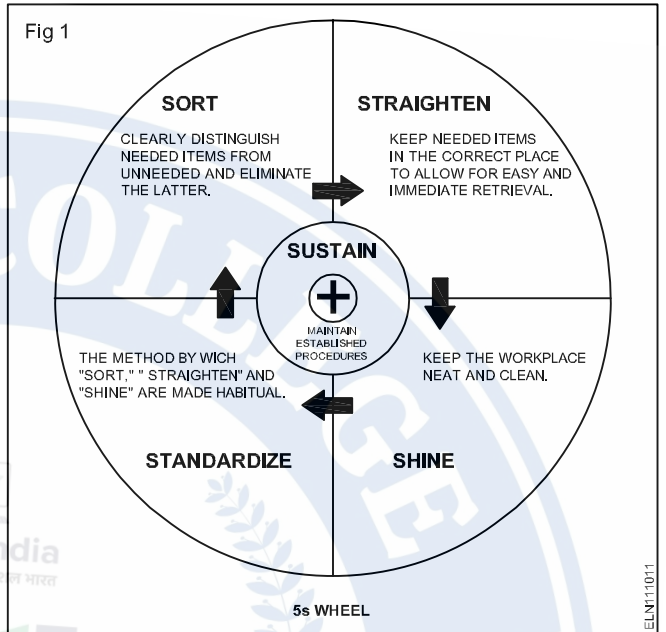

Trade hand tools - specification - standards - NEC code 2011 - lifting of heavy loads



Scan the QR Code to view the video for this exercise

Objectives: At the end of this lesson you shall be able to

- list the tools necessary for an electrician
- specify the tools and state the use of each tool.

It is important that the electrician uses proper tools for his work. The accuracy of workmanship and speed of work depend upon the use of correct tools.

Listed below are the most commonly used tools by electrician.

Pliers

The pliers used for electrical work will be of insulated grip.

1 Combination pliers with pipe grip, side cutter and insulated handle. BIS 3650 (Fig 1)

Size 150 mm, 200 mm etc.

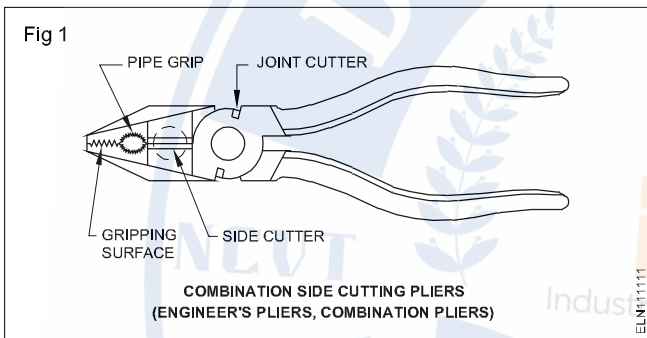

It is made of forged steel. It is used for cutting, twisting, pulling, holding and gripping small jobs in wiring assembly and repairing work.

2 Flat nose pliers BIS 3552 (Fig 2)

Size 100 mm, 150 mm, 200 mm etc.

Flat nose pliers are used for holding flat objects like thin plates etc.

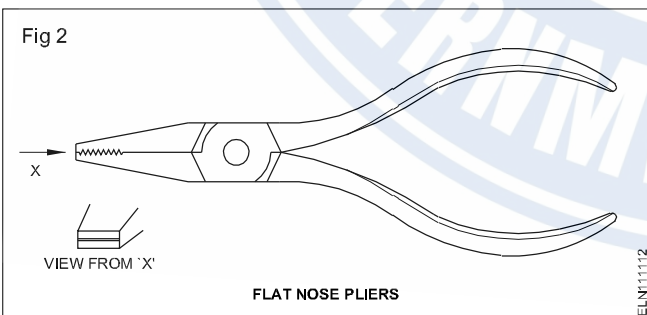

3 Side cutting pliers (Diagonal cutting pliers) BIS 4378 (Fig 3) Size 100 mm, 150 mm etc.

It is used for cutting copper and aluminium wires of smaller diameter (less than 4mm dia).

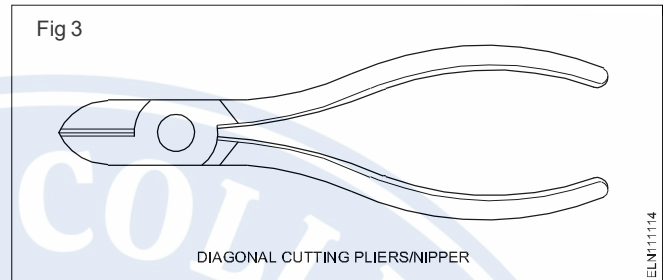

4 Screwdriver BIS 844 (Fig 4)

The screwdrivers used for electrical works generally have plastic handles and the stem is covered with insulating sleeves. The size of the screw driver is specified by its blade length in mm and nominal screwdriver's point size (thickness of tip of blade) and by the diameter of the stem.

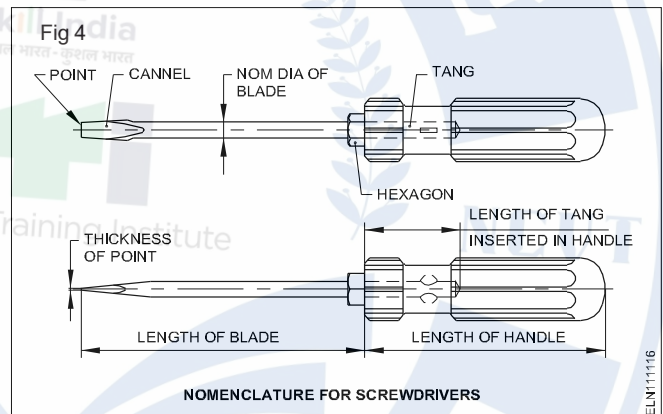

eg. 150 mm x 0.6 mm x 4 mm
200 mm x 0.8 mm x 5.5 mm etc.

The handle of screwdrivers is either made of wood or cellulose acetate.

5 Neon tester BIS 5579 - 1985 (Fig 5)

It is specified with its working voltage range 100 to 250 volts but rated to 500 V.

It consists of a glass tube filled with neon gas, and electrodes at the ends. To limit the current within 300 micro-amps at the maximum voltage, a high value resistance is connected in series with one of the electrodes.

6 Electrician's knife (Double blade) (Fig 6)

The size of the knife is specified by its largest blade length eg. 50 mm, 75 mm.

It is used for skinning the insulation of cables and cleaning the wire surface. One of the blades which is sharp is used for skinning the cable.

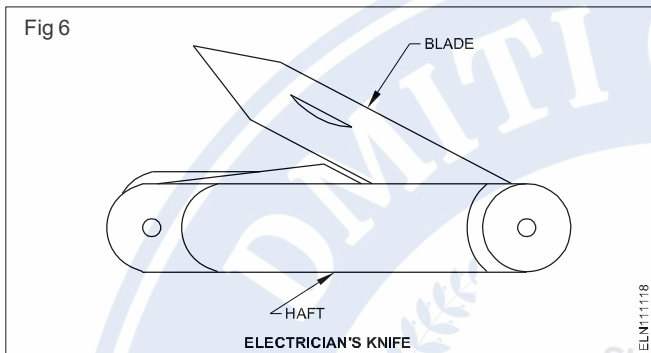
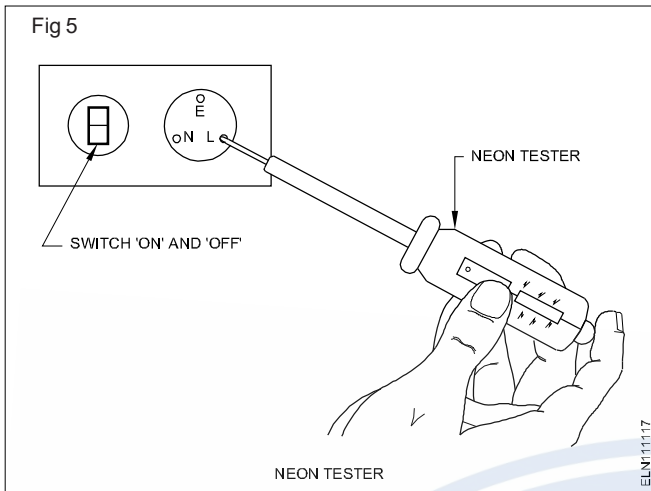

7 Hammer ball pein (Fig 7)

The size of the hammer is expressed in weight of the metal head. Eg. 125 gms, 250 gms etc.

The hammer is made out of special steel and the striking face is tempered. Used for nailing, straightening, and bending work. The handle is made of hard wood.

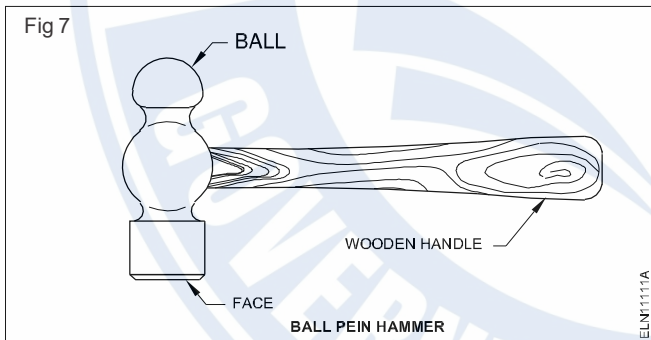

8 Try-square (Engineer's square) (Fig 8) BIS 2103

This is specified by its blade length.

- Eg. 50 mm x 35 mm
- 100 mm x 70 mm
- 150 mm x 100 mm etc.

Do not use it as a hammer.

9 Firmer chisel (Fig 9)

It has a wooden handle and a cast steel blade of 150 mm length. Its size is measured according to the width of the blade eg. 6 mm, 12 mm, 18 mm, 25 mm. It is used for chipping, scraping and grooving in wood.

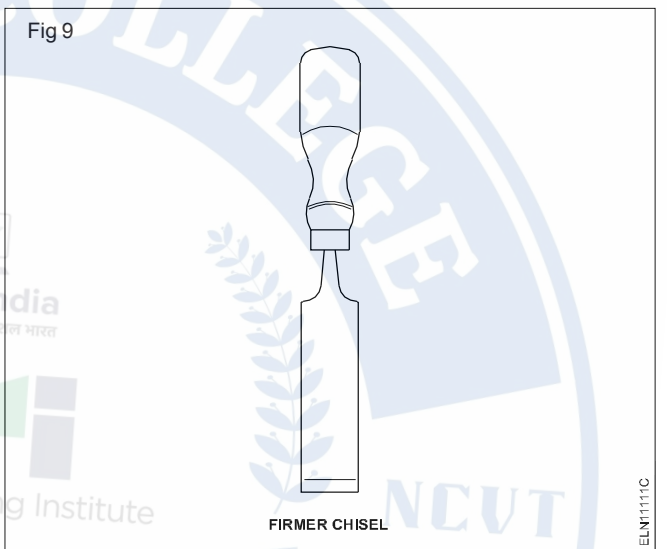
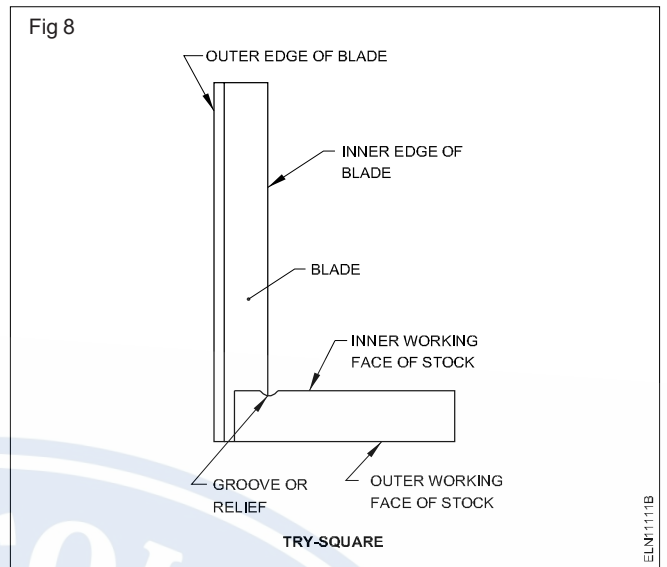

10 Tenon-saw (Fig 10) BIS 5123, BIS 5130, BIS 5031

Generally the length of a tenon-saw will be 250 or 300 mm. and has 8 to 12 teeth per 25.4 mm and the blade width is 10 cm. It is used for cutting thin, wooden accessories like wooden batten, casing capping, boards and round blocks.

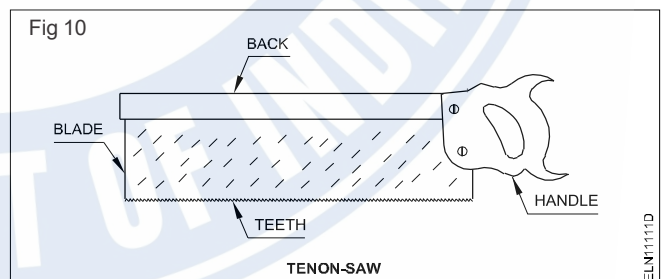

11 Files (Fig 11) BIS 1931

These are specified by their nominal length.

Eg. 150 mm, 200 mm, 250 mm 300 mm etc.

These files have different numbers of teeth designed to cut only in the forward stroke. They are available in different lengths and sections (Eg. flat, half round, round, square, triangular), grades like rough, bastard second cut and smooth and cuts like single and double cut.

These files are used to remove fine chips of material from metals. The body of the file is made of cast steel and hardened except the tang.

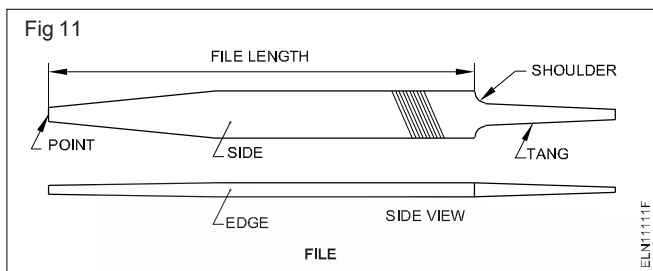

12 Bradawl square pointed (or poker) (Fig 12)

BIS 10375 - 1982

It is specified by its length and diameter eg. 150 mm x 6 mm.

It is a long sharp tool used for making pilot holes on wooden articles to fix screws.

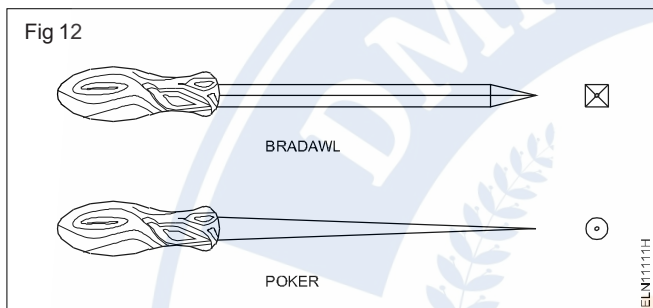

13 Centre punch (Fig 13) BIS 7177

The size is given by its length and diameter of the body.

Eg. 100 mm x 8 mm. The angle of the tip of the centre punch is 90°.

It is used for marking and punching pilot holes on metals. It is made of tool steel and the ends are hardened and tempered.

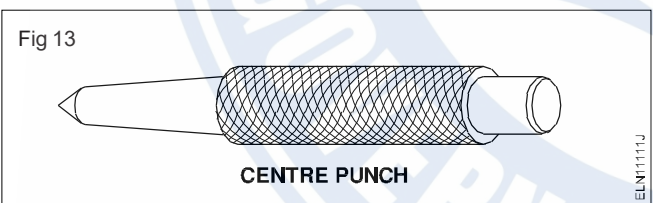

14 Mallet (Fig 14)

The mallet is specified by the diameter of the head or by the weight.

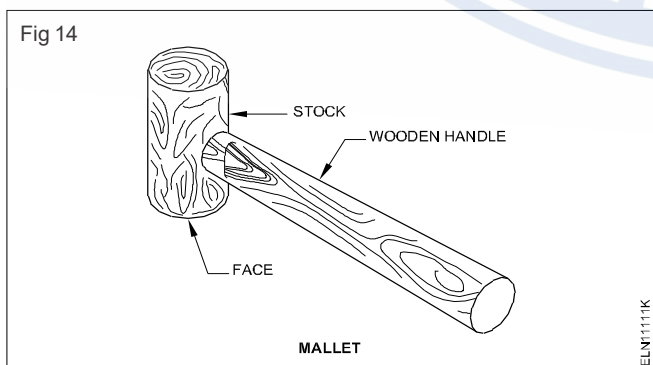

eg. 50 mm x 150 mm

75 mm x 150 mm or 500gms, 1 Kg.

It is made out of hard wood or nylon. It is used for driving the firmer chisel, and for straightening and bending of thin metallic sheets. Also it is used in motor assembly work.

15 Flat cold chisel (Fig 15) BIS 402

Its size is given by the nominal width and length.

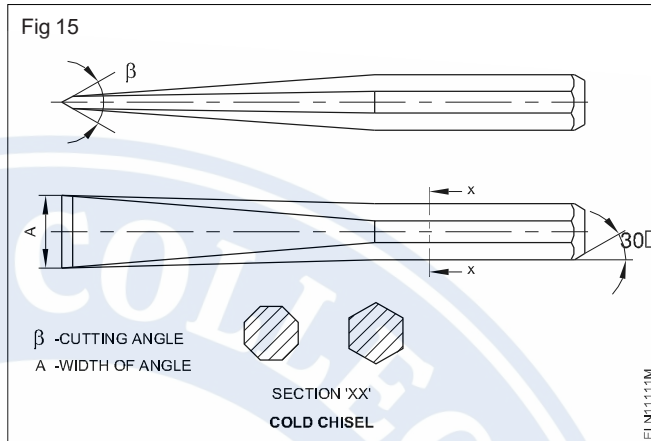

ie. 14 mm x 100 mm

15 mm x 150 mm

20 mm x 150 mm

The body shape of a cold chisel may be round or hexagon.

The cold chisel is made out of high carbon steel. Its cutting edge angle varies from 35° to 45°. The cutting edge of the chisel is hardened and tempered. This chisel is used for making holes on wall etc.

16 Rawl plug tool and bit (Fig 16)

Its size depends upon the number. As the number increases, the thickness of the bit as well as the plug also decreases. Eg. Nos.8, 10, 12, 14 etc.

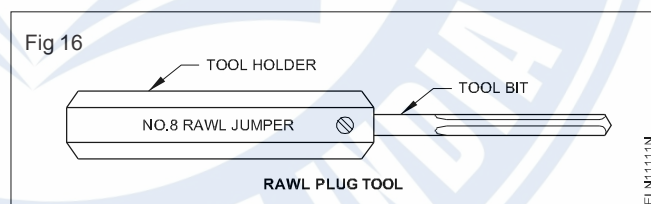

A rawl plug tool has two parts, namely the tool bit and tool holder. The tool bit is made of tool steel and the holder is made of mild steel. It is used for making holes in bricks, concrete wall and ceiling. Rawl plugs are inserted in them to fix accessories.

17 Spanner: double ended (Fig 17) BIS 2028

The size of a spanner is indicated so as to fit on the nuts. They are available in many sizes and shapes.

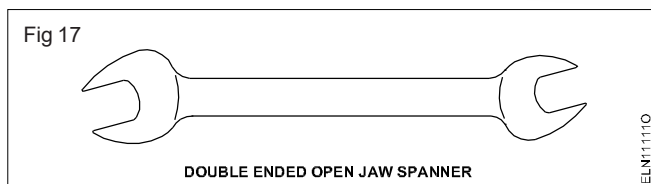

The sizes, indicated in double-ended spanners are

- 10-11 mm
- 12-13 mm
- 14-15 mm
- 16-17 mm
- 18-19 mm
- 20-22 mm.

For loosening and tightening of nuts and bolts, spanner sets are used. It is made out of cast steel. They are available in many sizes and may have single or double ends.

18 Hacksaw frame and blade

The hand hacksaw is used along with a blade to cut metals of different sections. It is also used to cut slots and contours.

Types of hacksaw frames

Bold frame: Only a particular standard length of blade can be fitted.

Adjustable frame (flat): Different standard lengths of blades can be fitted.

Adjustable frame tubular type (Fig 18): This is the most commonly used type. It gives a better grip and control while sawing.

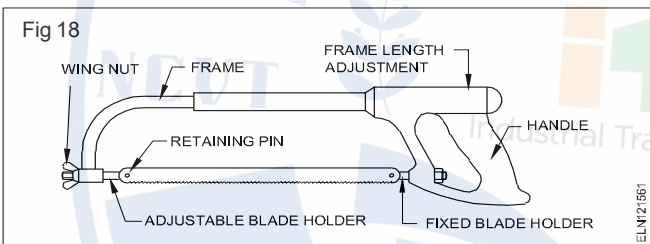

Hacksaw blades : The hacksaw blade is a thin, narrow, steel band with teeth and two pin holes at the ends. It is used along with a hacksaw frame. These blades are made of either low alloy steel (la) or high speed steel (hs) and are available in standard lengths of 250mm and 300mm.

For proper working, it is necessary to have frames of rigid construction.

Standard and standardisation

Objectives: At the end of this lesson you shall be able to

- state what is meant by standardisation and standard
- state the names of various standard organisation
- read and interpret the basic concept of electrical code 2011
- state the types of injury caused by the improper lifting method
- describe the procedure to be followed for moving heavy equipments.

Standardisation can be defined as the process of formulating and applying rules for an orderly approach to specific activity for the benefit of the user and the manufacturer, and in particular for the promotion of optimum overall economy taking due account of functional conditions and safety requirement.

Types of hacksaw blades

All-hard blades: The width between the pin holes is hardened all along the length of the blade.

Flexible blades: For these types of blades only the teeth are hardened. Because of their flexibility, these blades are useful for cutting along curved lines (Fig 19).

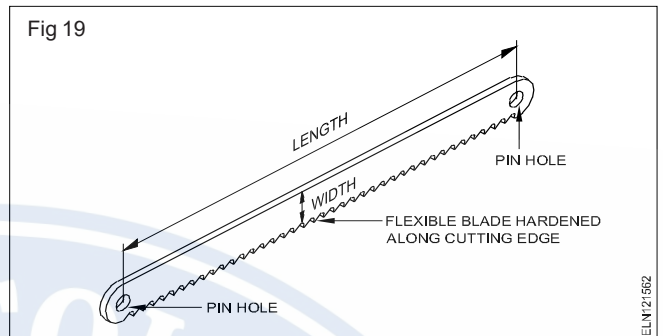

Saw blades for hacksaws are available with small and large cutting of teeth, depending on the type and size of material they are to cut. The size of the teeth is directly related to their pitch, which is specified by the number of teeth per 25mm of the cutting edge. Hacksaw blades are available in pitches of: (Fig 20)

- 14 teeth per 25 mm
- 18 teeth per 25 mm
- 24 teeth per 25 mm
- 32 teeth per 25 mm.

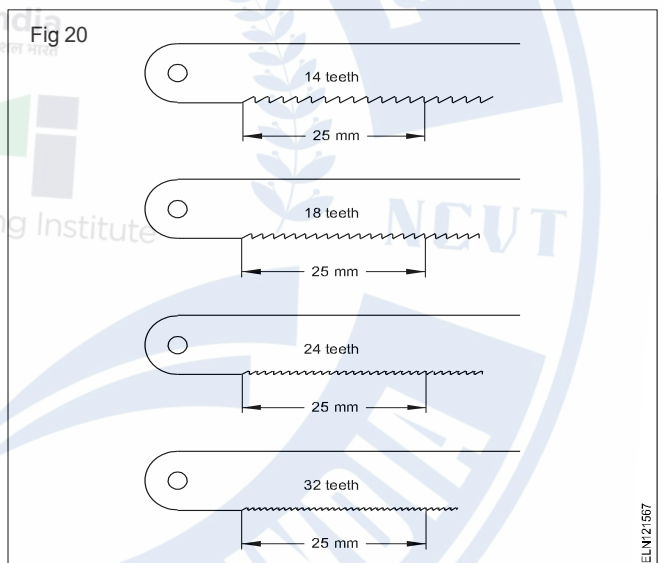

It is based on the consolidated results of science, technique and experience. It determines not only the basis for the present but also for future development, and to keep pace with progress.

The materials/tools/equipment produced in any country should be of certain standard. To meet this requirement,

the international organisation for standardization(ISO) is started and specifies the units of measurement, technology and symbols, products and processes, safety of persons and goods through a number of booklets coded with ISO number.

Standard can be defined as a formulation established verbally, in writing or by any other graphical method or by means of a model, sample or other physical means of representation to serve during a certain period of time for defining designating or specifying certain features of a unit or basis of measurement, physical object, an action, process, method, practice, capacity, function, duty, right of responsibility, a behaviour, an attitude a concept or a conception.

To sell Indian goods in the local and international market certain standardization methods are essential. The standard is specified by the **Bureau of Indian Standard BIS**(ISI) for various goods through their booklets. The BIS only certifies a good often the product meets the specification and passes necessary tests. The manufacturer allows to use the BIS(ISI) mark on the product only after BIS certification.

These are a number of organisation for standardisation throughout the world in different countries.

The standard organisation and the respective countries are given below:

BIS	- Bureau of Indian Standard (ISI) - India
ISO	- International standard Organisation
JIS	- Japanese Industrial Standard - Japan
BSI	- British Standards Institution BS(S) - Britain
DIN	- Deutsche Industrie Normen - Germany
GOST	- Russian
ASA	- American standards association - America

Advantages of BIS(ISI) certification marks scheme:

A number of advantages accrue to different sectors of economy from the BIS(ISI) certification marks scheme.

To manufacturers

- Streamlining of production processes and introduction of quality control system.
- Independent audit of quality control system by BIS
- Reaping of production economics accruing from standardization
- Better image of products in the market, both internal and overseas
- Winning for whole-salers, retailers and stockists consumer confidence and goodwill
- Preference for ISI-marked products by organised purchasers, agencies of Central and State Governments, local bodies, public and private sector undertakings etc. Some organised purchasers offer even higher price for ISI-marked goods.
- Financial incentives offered by the Industrial Development Bank of India (IDBI) and nationalised banks.

To consumers

- Conformity with Indian Standards by an independent technical, National Organisation
- Help in choosing a standard product
- Free replacement of ISI-marked products in case of their being found to be of substandard quality
- Protection from exploitation and deception
- Assurance of safety against hazards to life and property

Introduction to National Electrical Code - 2011

National Electrical Code - 2011

National electrical code describes several Indian standards deciding with the various aspects relating to electrical installation practice. It is therefore recommended that individual parts/ sections of the code should be read in conjunction with the relevant Indian standards.

There are 8 parts and each part contains number of sections. Each section refers the description of the electrical item/ devices, equipment etc.

Here, 20 sections of the part - 1 are described which aspect it covers

In part 1, 20 sections are there. Each section reference is given below.

Section 1 part 1/ section 1 of the code describes the scope of the NEC.

Section 2 covers definition of items with references.

Section 3 covers graphical symbols for diagrams, letter symbols and signs which may be referred for further details.

Section 4 covers guidelines for preparation of diagrams, chart and tables in electro technology and for marking of conductors.

Section 5 covers units and systems of measurement in electro technology.

Section 6 covers standard values of AC and DC distribution voltage preferred values of current ratings and standard systems frequency.

Section 7 enumerates the fundamental principles of design and execution of electrical installation.

Section 8 covers guidelines for assessing the characteristics of buildings and the electrical installation there in.

Section 9 Covers the essential design and constructional requirement for electrical wiring installation.

Section 10 covers guidelines and general requirements associated with circuit calculators.

Section 11 covers requirements of installation work relating to building services that use electrical power.

Section 12 covers general criteria for selection of equipment.

Section 13 covers general principles of installation and guide lines on initial testing before commissioning.

Section 14 covers general requirements associated with earthing in electrical installations. Specific requirements for earthing in individual installations are covered in respective parts of the code.

Section 15 covers guidelines on the basic electrical aspects of lightning protective systems for buildings and the electrical installation forming part of the system.

Section 16 covers the protection requirements in low voltage electrical installation of buildings.

Section 17 covers causes for low power factor and guidelines for use of capacitors to improve the same in consumer installations.

Section 18 covers the aspects to be considered for selection of equipment from energy conservation point of view and guidance on energy audit.

Section 19 covers guidelines on safety procedures and practices in electrical work.

Section 20 gives frequently referred tables in electrical engineering work.

The above description is part 1 only you can refer remaining parts and section for other electrical installation, items devices and equipments.

Lifting and handling of loads

Many of the accidents reported involve injuries caused by lifting and carrying loads. A electrician may need to install motors, lay heavy cables, do wiring, which may involve a lot of lifting and carrying of loads. Wrong lifting techniques can result in injury.

A load need not necessarily be very heavy to cause injury. The wrong way of lifting may cause injury to the muscles and joints even though the load is not heavy.

Further injuries during lifting and carrying may be caused by tripping over an object and falling or striking an object with a load.

Crushing of feet or hands

Feet or hands should be so positioned that they will not be trapped by the load. Timber wedges can be used when raising and lowering heavy loads to ensure fingers and hands are not caught and crushed.

Safety shoes with steel toe caps will protect the feet. (Fig 1)

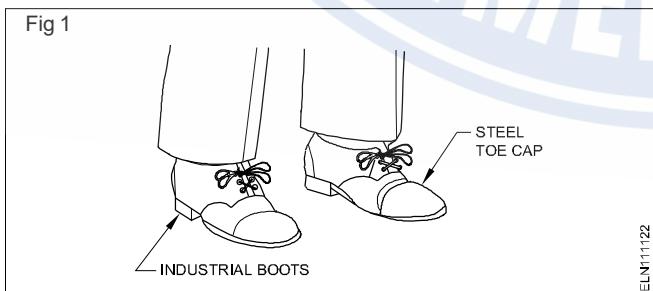

Preparaing to lift : Load which seems light enough to carry at first will become progressively heavier, the farther you have to carry it.

The person who carries the load should always be able to see over or around it.

The weight that a person can lift will vary according to:

- Age
- Physique, and
- Condition

It will also depend on whether one is used to lifting and handling heavy loads.

What makes an object difficult to lift and carry?

- 1 Weight is not the only factor which makes it difficult to lift and carry.
- 2 The size and shape can make an object awkward to handle.
- 3 Loads high require the arms to be extended in front of the body, place more strain on the back and stomach.
- 4 The absence of hand holds or natural handling points can make it difficult to raise and carry the object.

Correct manual lifting techniques

- 1 Approach the load squarely, facing the direction of travel
- 2 The lift should start with the lifter in a balanced squatting position, with the legs slightly apart and the load to be lifted held close to the body.
- 3 Ensure that a safe firm hand grip is obtained. Before the weight is taken, the back should be straightened and held as near the vertical position as possible. (Fig 2)
- 4 To raise the load, first straighten the legs. This ensures that the lifting strain is being correctly transmitted and is being taken by the powerful thigh muscles and bones.
- 5 Look directly ahead, not down at the load while straightening up, and keep the back straight; this will ensure a smooth, natural movement without jerking or straining (Fig 3)
- 6 To complete the lift, raise the upper part of the body to the vertical position. When a load is near to an individual's maximum lifting capacity it will be necessary to lean back on the hips slightly (to counter balance the load) before straightening up. (Fig 4)

Keeping the load well near to the body, carry it to the place where it is to be set down. When turning, avoid twisting from the waist - turn the whole body in one movement.

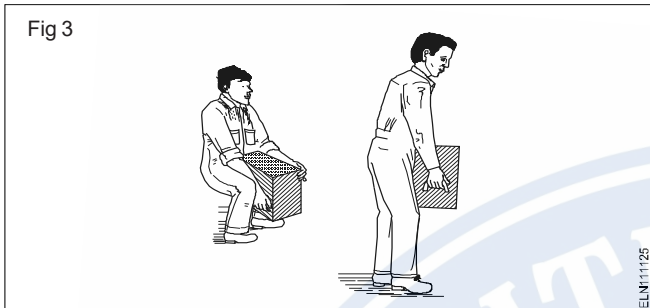
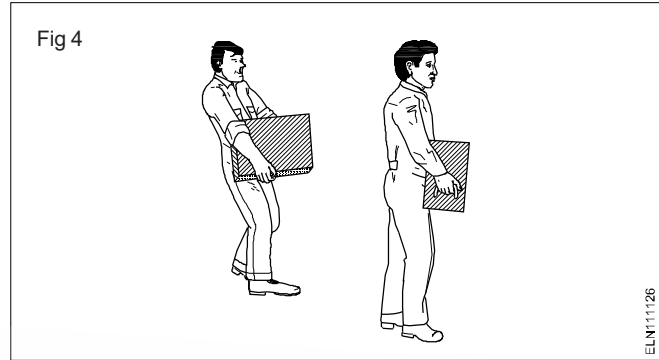
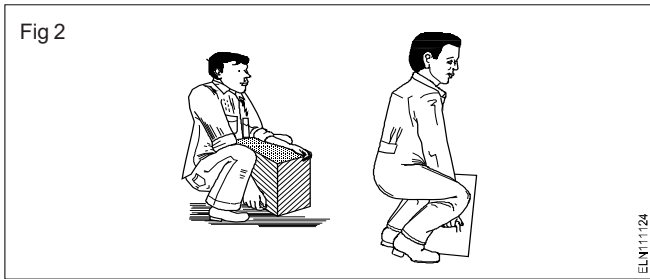

Drills and drilling machines

Objectives : At the end of this lesson you shall be able to

- state the functions of drills
- name the parts of a drill
- name the drill bit holders
- state the uses of countersinking bits.

Drill: Drilling is a process of making holes on workpieces by using a drill.

Parts of a drill (Fig 1)

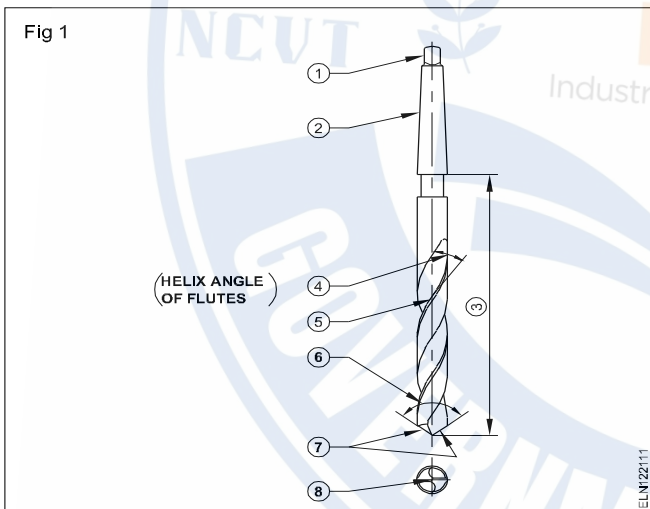

- Tang (1)
- Shank (2)
- Body (3)
- Flute (4)
- Land (5)
- Point angle (6)
- Cutting lip (7)
- Chisel edge (8)

Tang: Tang is the part that fits into the slot of the drilling machine spindle.

Shank: This is the driving end of the drill which is fitted on the machine. Shanks are of two types.

- Taper shank: for larger diameter drills.
- Straight shank: for smaller diameter drills.

The shank may be parallel or tapered. (Figs 2 & 3) Drills with parallel or straight shanks are made in small sizes, up to 12mm (1/2 in) diameter and the shank has the same diameter as the flutes.

Taper shank drills are made in sizes from 3mm (1/8 in) diameter up to 50mm (2 in) diameter.

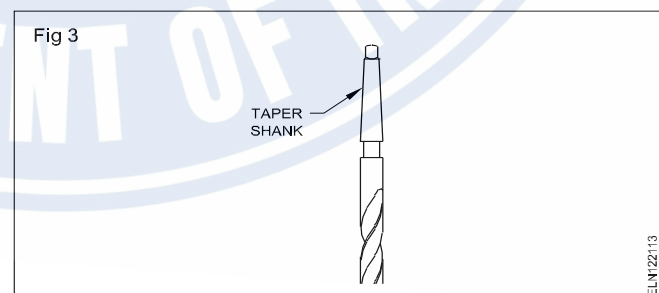
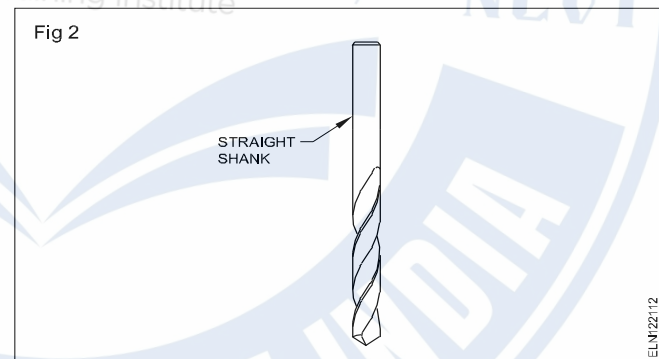

Body: The body is the portion between the point and shank.

Flutes: Flutes are the spiral grooves which run to the length of the drill.

The flutes help:

- to form the cutting edges
- to curl the chips and allow them to come out (Fig 4)

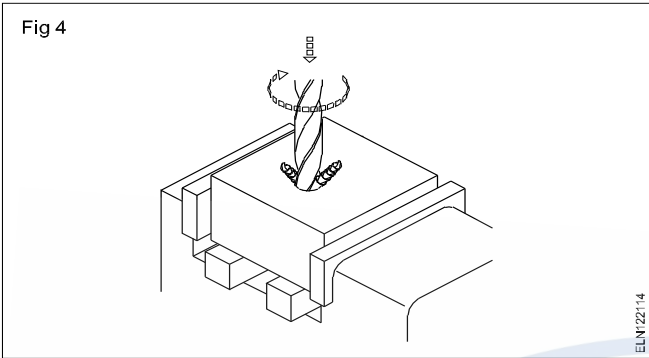

- the coolant to flow to the cutting edge.

Land/margin: Land/margin is the narrow strip which extends to the entire length of the flutes. The diameter of the drill is measured across the land/margin.

Body clearance: Body clearance is the part of the body which is reduced in diameter to cut down the friction between the drill and the hole being drilled.

Web: Web is the metal column which separates the flutes. It gradually increases in thickness towards the shank.

Drill bit holder

Drill chuck: Drill chuck is attached to the main spindle for straight shank basis. (Fig 5)

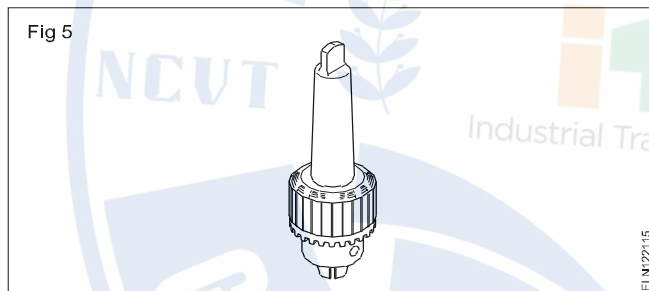

Sleeve: This is used to match bit tapers and the spindle taper holes. (Fig 6)

Socket: This is used when the main spindle length is too short, and the bit is changed frequently. (Fig 7)

Taper shank drills are held in taper sockets in the machine. (Fig 8)

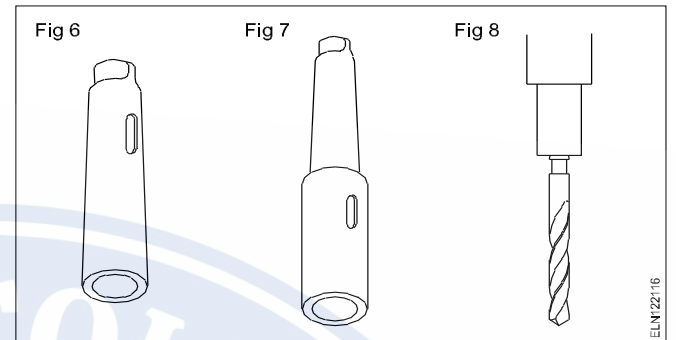

The tang on a taper shank drill enables easy removal of the drill from the socket at the end of the drilling work. This is done using a drift. (Fig 9) The tang also serves to prevent the drill from rotating in the socket.

Use of a coolant: A coolant is used to cool the cutting tool and the job.

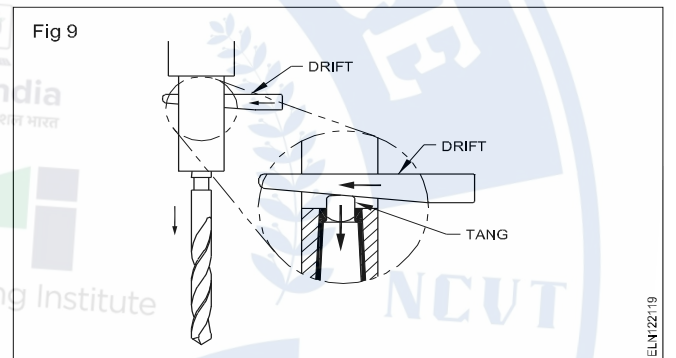

Drilling machines

Objectives: At the end of this lesson you shall be able to

- state the types of hand drilling machines and their uses
- state the parts of bench and pillar drilling machine
- explain the features of machine vice

Making holes in sheet metal by using solid punches is a slow and inefficient process.

It is necessary to drill holes when working with heavy material.

The holes can be drilled by hand or by machine. When drilling by hand, a hand drilling machine (Fig 1) or the electric hand drilling machine (Fig 2) is used.

Twist drills are used as a cutting tool for drilling holes. The hand drill is used for drilling holes up to 6.5 mm diameter.

The portable electric hand drilling machine is a very popular and useful power tool. It comes in different sizes and capacities.

The handle shown in Fig 2 is called a pistol grip handle.

The parts of an electric hand machine are shown in Fig 2.

Precautions to be observed : Make sure the holes are properly located and punched with a centre punch.

Be sure the drill is properly centred in the chuck by turning (rotating).

Be sure the work is mounted properly in a holding device such as a vice or 'G' clamp.

Check the centering of the drill after the point has just started in the metal. Relocate the hole with a centre punch, if necessary. Feed the drill with a light, even pressure.

Types of Electric Drilling Machines: Some of the electric drilling machines are listed here.

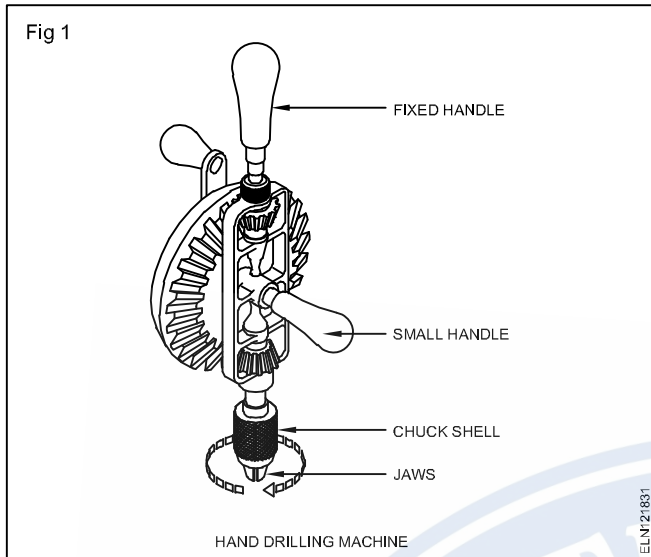

- The sensitive bench drilling machine
- The pillar drilling machine
- The radial arm drilling machine. (Radial drilling machine)

(As you are not likely to use the column and radial type of drilling machines now, only the sensitive and pillar type machines are explained here.)

Sensitive bench drilling machine: The simplest type of sensitive bench drilling machine is shown in the (figure 3) with its various parts marked. This machine is used for light duty work. (Fig 3)

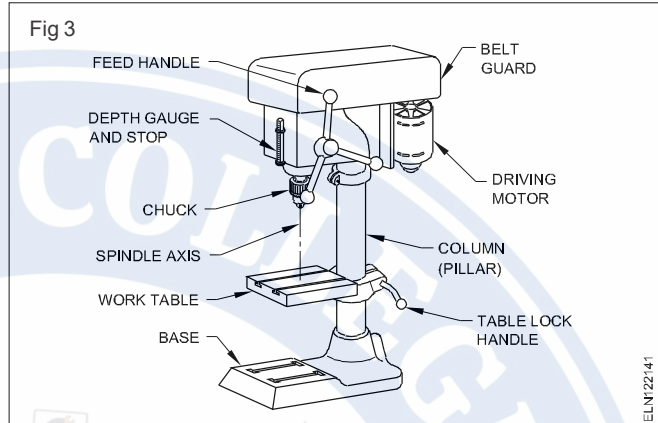
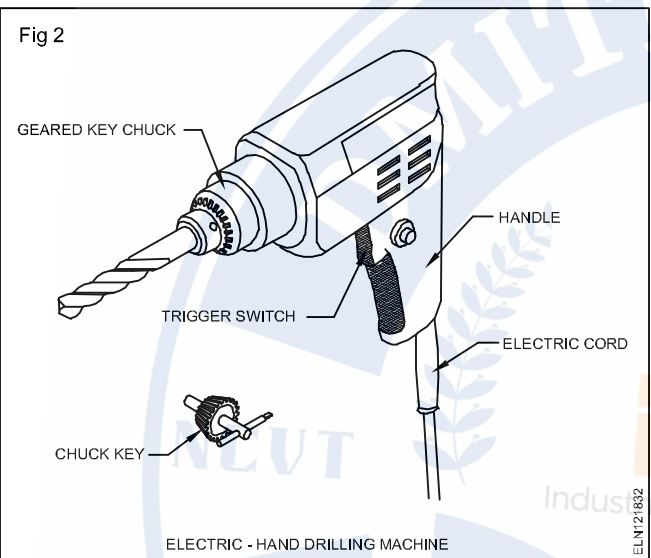

This machine is capable of drilling holes up to 12.5mm diameter. The drills are fitted in the chuck or directly in the tapered hole of the machine spindle.

The pillar drilling machine: This is an enlarged version of the sensitive bench drilling machine. These drilling machines are mounted on the floor and are driven by more powerful electric motors. They are used for heavy duty work. Pillar drilling machines are available in different sizes. Large machines are provided with a rack and pinion mechanism for moving the table for setting the work.